

Table of Contents

1. Introduction	7
1.1 Overview	7
1.2 Specifications	8
1.3 Features	8
1.4 Applications	9
1.5 Deep sleep mode and working mode	9
1.6 Button and LEDs	10
1.7 BLE connection	11
1.8 Pin definitions	11
1.8.1 SW2 Jumper (Define UART level to external Sensor)	12
1.9 Wiring of DS18B20 temperature sensor	12
1.10 Mechanical drawings	14
1.11 Cable drawings	14
2. Registering WQS-LB/LS with a LoRaWAN Network Server	15
2.1 Registration information	15
2.1.1 Registering with The Things Stack	16
2.1.2 Add WQS-LB/LS to The Things Stack	16
2.1.3 Uplink Decoder in The Things Stack	22
2.2 Uplink payload	22
2.2.1 Uplink FPort=5, Device status	22
2.2.3 Uplink FPort=2, Real time sensor value	24
2.3 Uplink FPort=3, Datalog	25
2.3.1 How datalog works	25
2.3.2 Enable Datalog	25
2.3.3 Unix TimeStamp	25
2.3.4 Datalog Uplink payload (FPORT=3)	26
2.4 Integrating data with IoT platforms	27
2.4.1 Integrate and show data on ThingsEye	28
2.4.2 Integrate and show data on TagoIO	38

3. Configure the WQS-LB/LS using AT commands or LoRaWAN downlinks	41
3.1 Set transmit interval time	41
3.2 Set interrupt mode	42
3.3 Set power output duration	43
3.4 Sensor Calibration Commands	44
3.5 RS485 Test Command	45

4. Water Quality Sensors	45
4.1 pH Sensor	45
4.1.1 Features	45
4.1.2 Specifications	46
4.1.3 Dimensions	46
4.1.4 Installation	46
4.1.5 Maintenance	48
4.1.6 Calibration	48
4.2 EC Sensor	49
4.2.1 Features	49
4.2.2 Specifications	49
4.2.3 Dimensions	50
4.2.4 Installation	50
4.2.5 Maintenance	53
4.2.6 Calibration	54
4.3 ORP Sensor	54
4.3.1 Features	55
4.3.2 Specifications	55
4.3.3 Dimensions	55
4.3.4 Installation Note	55
4.3.5 Maintenance	56
4.3.6 Calibration	57
4.4 Dissolved Oxygen Sensor	57
4.4.1 Features	58
4.4.2 Specifications	58
4.4.3 Dimensions	58
4.4.4 Instructions for use and maintenance	59
4.4.5 Precautions	59
4.5 Turbidity Sensor	59
4.5.1 Features	59
4.5.2 Specifications	60
4.5.3 Dimensions	60
4.5.4 Instructions for use and maintenance	60
4.5.5 Calibration	61
4.5.6 Precautions	61

5. DR-CL Water CL Probe	61
5.1 Specification:	61
5.2 Mechanical Drawing	62
5.3 Maintenance	62
6. More detailed information about water quality sensors	63
7. OTA Firmware update	63
8. FAQ	63
8.1 External Power Supply Connection (For Battery Depletion/Multi-Sensor Use)	64
8.2 Why is there no LED response when I press the button on the solar panel model?	65
9. Order Info	65
9.1 Main Unit	65
9.2 Sensors	65
10. Support	66



Table of Contents:

- [1. Introduction](#)
 - [1.1 Overview](#)
 - [1.2 Specifications](#)
 - [1.3 Features](#)
 - [1.4 Applications](#)
 - [1.5 Deep sleep mode and working mode](#)
 - [1.6 Button and LEDs](#)
 - [1.7 BLE connection](#)
 - [1.8 Pin definitions](#)
 - [1.8.1 SW2 Jumper \(Define UART level to external Sensor\)](#)
 - [1.9 Wiring of DS18B20 temperature sensor](#)
 - [1.10 Mechanical drawings](#)
 - [1.11 Cable drawings](#)
- [2. Registering WQS-LB/LS with a LoRaWAN Network Server](#)
 - [2.1 Registration information](#)
 - [2.1.1 Registering with The Things Stack](#)
 - [2.1.2 Add WQS-LB/LS to The Things Stack](#)
 - [2.1.2.1 Creating an application](#)
 - [2.1.2.2 Adding manually](#)
 - [2.1.2.3 Power on the WQS-LB/LS](#)
 - [2.1.3 Uplink Decoder in The Things Stack](#)
 - [2.2 Uplink payload](#)
 - [2.2.1 Uplink FPort=5, Device status](#)
 - [2.2.3 Uplink FPort=2, Real time sensor value](#)
 - [2.3 Uplink FPort=3, Datalog](#)
 - [2.3.1 How datalog works](#)
 - [2.3.2 Enable Datalog](#)
 - [2.3.3 Unix TimeStamp](#)
 - [2.3.4 Datalog Uplink payload \(FPORT=3\)](#)

- [2.4 Integrating data with IoT platforms](#)
 - [2.4.1 Integrate and show data on ThingsEye](#)
 - [2.4.1.1 Configuring The Things Stack](#)
 - [2.4.1.2 Configuring ThingsEye.io](#)
 - [2.4.1.3 Viewing integration details](#)
 - [2.4.1.4 Viewing events](#)
 - [2.4.1.5 Deleting an integration](#)
 - [2.4.1.6 Creating a dashboard](#)
 - [2.4.2 Integrate and show data on TagoIO](#)
- [3. Configure the WQS-LB/LS using AT commands or LoRaWAN downlinks](#)
 - [3.1 Set transmit interval time](#)
 - [3.2 Set interrupt mode](#)
 - [3.3 Set power output duration](#)
 - [3.4 Sensor Calibration Commands](#)
 - [3.5 RS485 Test Command](#)
- [4. Water Quality Sensors](#)
 - [4.1 pH Sensor](#)
 - [4.1.1 Features](#)
 - [4.1.2 Specifications](#)
 - [4.1.3 Dimensions](#)
 - [4.1.4 Installation](#)
 - [4.1.5 Maintenance](#)
 - [4.1.6 Calibration](#)
 - [4.2 EC Sensor](#)
 - [4.2.1 Features](#)
 - [4.2.2 Specifications](#)
 - [4.2.3 Dimensions](#)
 - [4.2.4 Installation](#)
 - [4.2.5 Maintenance](#)
 - [4.2.6 Calibration](#)
 - [4.3 ORP Sensor](#)
 - [4.3.1 Features](#)
 - [4.3.2 Specifications](#)
 - [4.3.3 Dimensions](#)
 - [4.3.4 Installation Note](#)
 - [4.3.5 Maintenance](#)
 - [4.3.6 Calibration](#)
 - [4.4 Dissolved Oxygen Sensor](#)
 - [4.4.1 Features](#)
 - [4.4.2 Specifications](#)
 - [4.4.3 Dimensions](#)
 - [4.4.4 Instructions for use and maintenance](#)
 - [4.4.5 Precautions](#)
 - [4.5 Turbidity Sensor](#)
 - [4.5.1 Features](#)
 - [4.5.2 Specifications](#)
 - [4.5.3 Dimensions](#)
 - [4.5.4 Instructions for use and maintenance](#)
 - [4.5.5 Calibration](#)

- [4.5.6 Precautions](#)
- [5. DR-CL Water CL Probe](#)
 - [5.1 Specification:](#)
 - [5.2 Mechanical Drawing](#)
 - [5.3 Maintenance](#)
- [6. More detailed information about water quality sensors](#)
- [7. OTA Firmware update](#)
- [8. FAQ](#)
 - [8.1 External Power Supply Connection \(For Battery Depletion/Multi-Sensor Use\).](#)
 - [8.2 Why is there no LED response when I press the button on the solar panel model?](#)
- [9. Order Info](#)
 - [9.1 Main Unit](#)
 - [9.2 Sensors](#)
- [10. Support](#)

1. Introduction

1.1 Overview

The Dragino WQS-LB/LS is an advanced LoRaWAN end device designed for comprehensive water quality monitoring across various applications. It is ideal for ensuring water quality in **tap water**, **industrial water**, **environmental water**, and **wastewater**, offering precise and reliable measurements to meet water quality standards.

Communication between **all water quality sensors and nodes** is implemented through the **RS485 bus** and the **Modbus protocol** is used as the communication standard. This design has **high reliability and strong anti-interference ability**, and is especially suitable for data acquisition and transmission in industrial environments or complex scenarios. The RS485 bus supports **multi-point communication** and can connect multiple sensors and node devices to form a stable data communication network.

The system's **modular design** allows each water quality sensor to be **disassembled and installed independently**. When a sensor needs to be replaced or maintained, simply remove the target sensor from the current RS485 bus network. These sensors also allow **easy access to other reading devices that support the RS485 interface**. For example, you can install sensors into different data acquisition terminals, controllers, or monitoring systems **without additional hardware modifications or complex configuration tweaks**.

Note1: The method of use is that the probe is in direct contact with the water quality. Before using the sensor probe, its protective cover and blue foam cushioning pad must be completely removed. These protective components are designed for transportation and storage, and can effectively resist factors such as physical collision that damage the probe.

Note2: Because the probe needs to adapt to the new water quality environment, the data collected at the beginning will be inaccurate. After standing in the new water quality for two hour, the data collected by the equipment will be more accurate.

Key Features:

- **Supports 1 to 3 Probes:**

Compatible with a range of water quality probes, including EC (Electrical Conductivity), pH, DO (Dissolved Oxygen), ORP (Oxidation-Reduction Potential), and TS (Total Solids) probes.

- **Wireless Data Transmission:**

Measures water quality parameters and uploads the data wirelessly to a LoRaWAN server.

- **Easy Configuration and Updates:**

Supports BLE (Bluetooth Low Energy) configuration and wireless OTA (Over-the-Air) updates for convenient setup and maintenance.

- **Long Battery Life:**

Powered by an 8500mAh Li-SOCl₂ battery, designed for long-term use, with a lifespan of up to several years.

1.2 Specifications

Common DC Characteristics:

- Supply Voltage: Built-in Battery, 2.5v ~ 3.6v
- Operating Temperature: -40 ~ 85°C

I/O Interface:

- Battery controllable output (2.6v ~ 3.6v depends on battery)
- +12v controllable output
- 1 x RS485 Interface
- 1 x UART Interface , 3.3v or 5v or 12v
- 1 x Interrupt or Digital IN pins
- 1 x I2C Interface
- 1 x one wire interface

LoRa Spec:

- Frequency Range, Band 1 (HF): 862 ~ 1020 Mhz
- Max +22 dBm constant RF output vs.
- RX sensitivity: down to -139 dBm.
- Excellent blocking immunity

Battery:

- Li/SOCl₂ un-chargeable battery
- Capacity: 8500mAh
- Self-Discharge: <1% / Year @ 25°C
- Max continuous current: 130mA
- Max boost current: 2A, 1 second

Power Consumption

- Sleep Mode: 5uA @ 3.3v
- LoRa Transmit Mode: 125mA @ 20dBm, 82mA @ 14dBm

1.3 Features

- LoRaWAN 1.0.3 Class A

- Frequency Bands: CN470/EU433/KR920/US915/EU868/AS923/AU915/IN865/RU864/MA869
- Ultra-low power consumption
- Measure water quality and provide information for water quality conditions
- Support EC / PH / DO / ORP / TS / CL Type Water Quality Probe
- Support 1 ~ 3 probes
- Support Bluetooth v5.1 and LoRaWAN remote configure
- Support wireless OTA update firmware
- AT Commands to change parameters
- Uplink on periodically
- Downlink to change configure
- 8500mAh Li/SOCI2 Battery (WQS-LB)
- Solar panel + 3000mAh Li-ion battery (WQS-LS)

1.4 Applications

- Smart Buildings & Home Automation
- Logistics and Supply Chain Management
- Smart Metering
- Smart Agriculture
- Smart Cities
- Smart Factory

1.5 Deep sleep mode and working mode



The WQS-LB/LS has two modes:

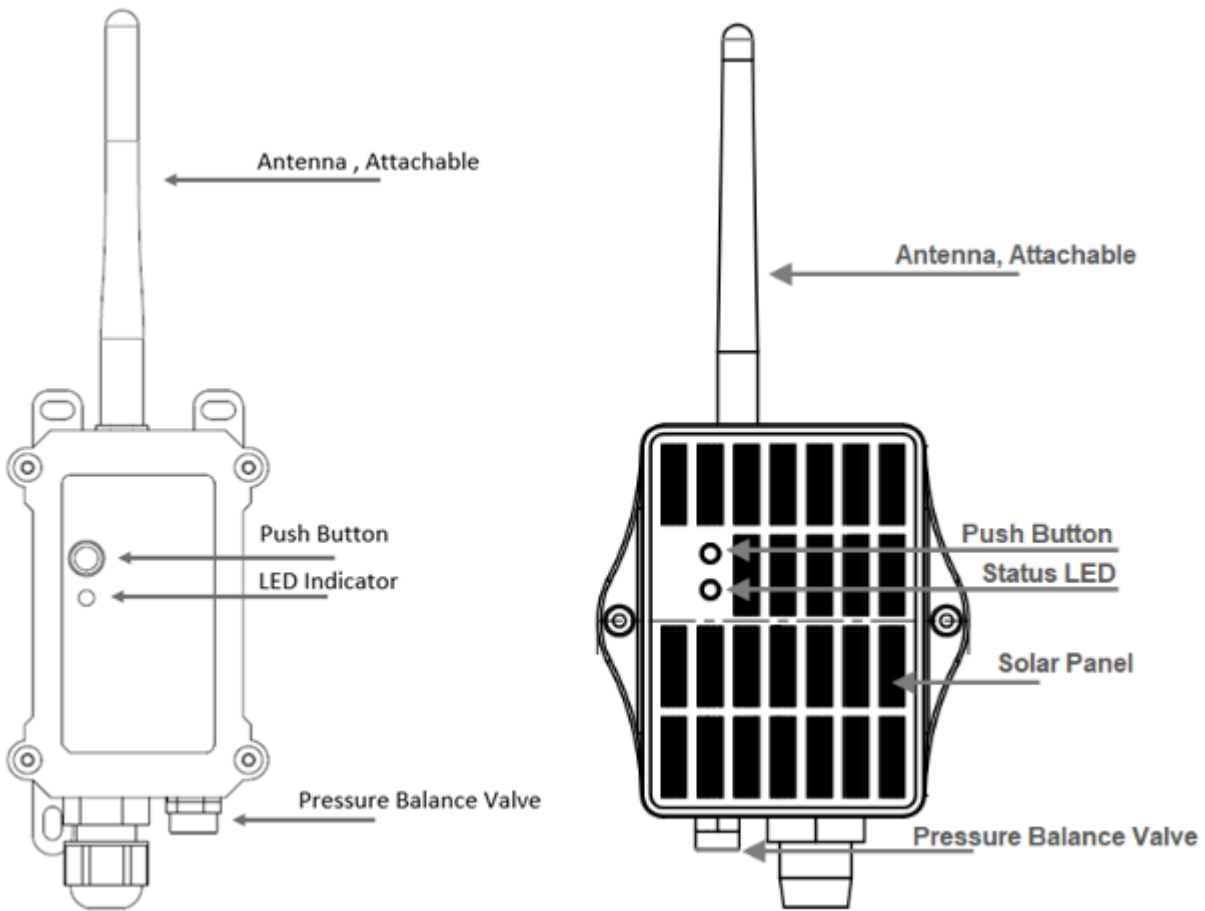

Deep Sleep Mode: In this mode, the sensor's LoRaWAN functionality is disabled. It is intended for storage and shipping to conserve battery life.

Working Mode: In this mode, the sensor operates as a LoRaWAN device, connecting to a LoRaWAN network and transmitting sensor data to a server. The sensor enters IDLE mode between each sampling, transmission (TX), and reception (RX) cycle. In IDLE mode, the sensor consumes the same amount of power as it does in Deep Sleep mode.

1.6 Button and LEDs



Behavior on ACT	Function	Action
  1~3s	Send an uplink	<p>If the sensor is already joined to a LoRaWAN network, it will send an uplink packet, and the blue LED will blink once.</p> <p>At the same time, the BLE module will activate, allowing the user to connect via BLE to configure the device.</p>

	Active Device	<p>The GREEN LED will blink rapidly 5 times, indicating that the device has entered OTA mode for 3 seconds. It will then begin the process of joining the LoRaWAN network.</p> <p>Once the device successfully joins the network, the green LED will remain solid for 5 seconds.</p> <p>After the sensor is activated, the BLE module will be enabled, allowing the user to connect via BLE to configure the device, regardless of whether the device has joined the LoRaWAN network or not.</p>
	Deactivate Device	<p>The RED LED will remain solid for 5 seconds, indicating that the device is in Deep Sleep Mode.</p>

1.7 BLE connection

The RS485-LB/LS supports remote configuration via Bluetooth Low Energy (BLE). BLE can be used to configure sensor parameters and view console output from the sensor.

The BLE module activates in the following cases:

- When the button is pressed to send an uplink.
- When the button is pressed to activate the device.
- When the device powers on or resets.

If no BLE connection is established within 60 seconds, the sensor automatically disables the BLE module to enter low-power mode.

1.8 Pin definitions

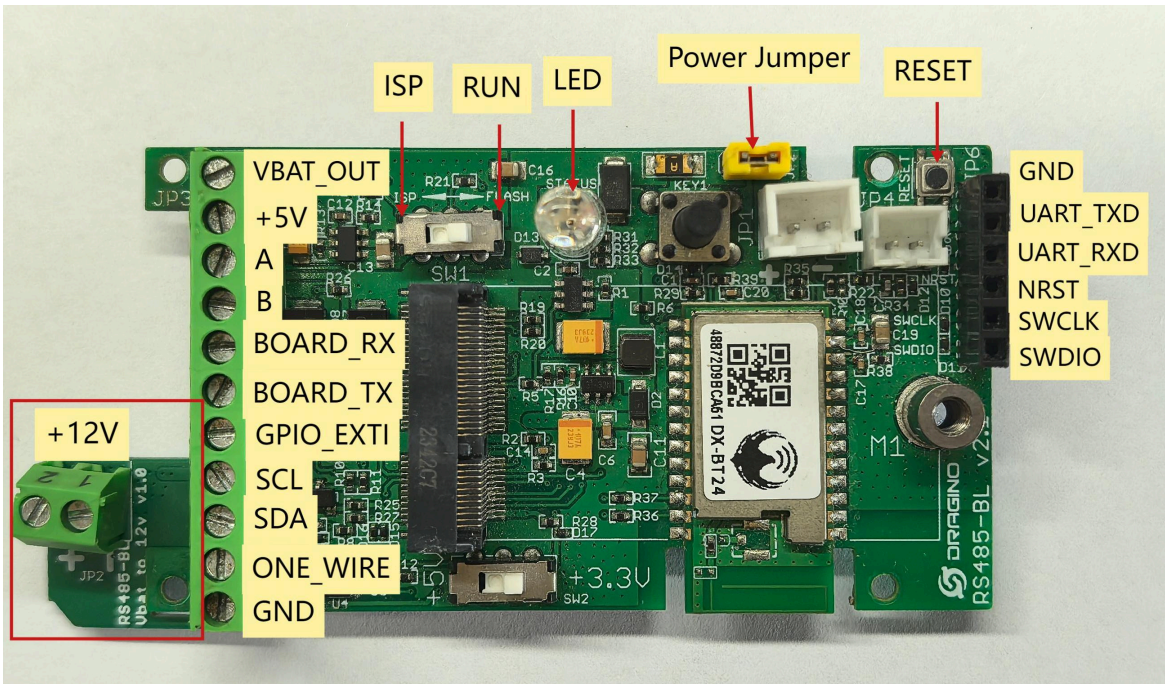

1.8.1 SW2 Jumper (Define UART level to external Sensor)

SW2 defines the voltage level of the **BOARD_RX** and **BOARD_TX** pins. It should match the voltage level of the external sensor.

1.9 Wiring of DS18B20 temperature sensor

The WQS-LB/LS supports connection to the external temperature sensor DS18B20. The wiring method is as follows:

DS18B20 sensor<--->WQS-LB Motherboard
Power<--->VBAT_OUT
Data<--->ONE_WIRE
GND<---->GND

DS18B20
temperature sensor

LA66
module

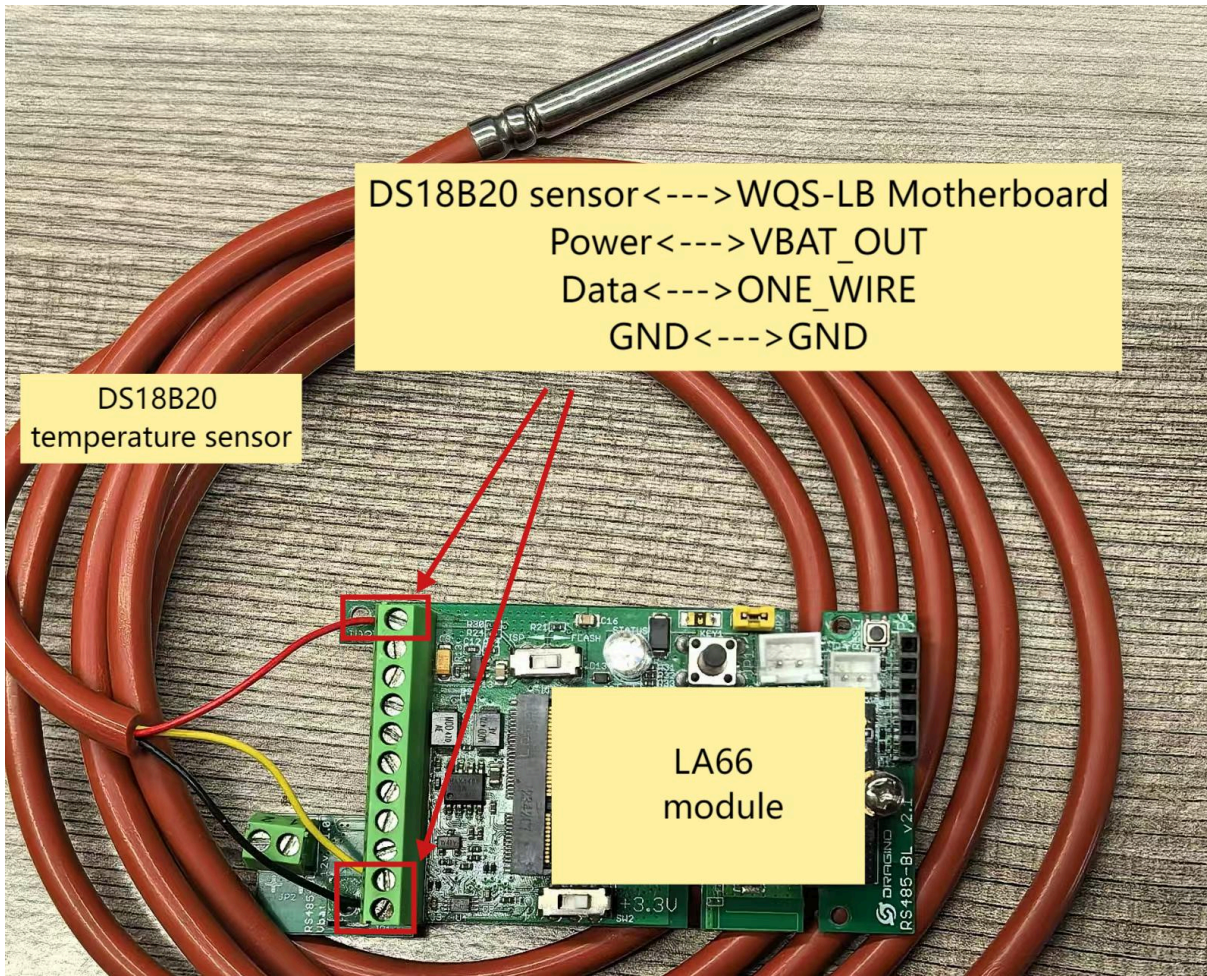

1.10 Mechanical drawings

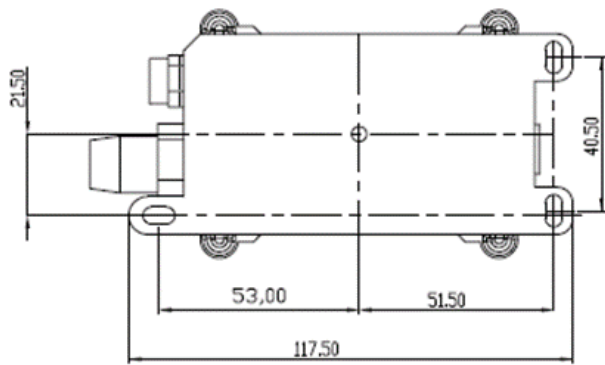
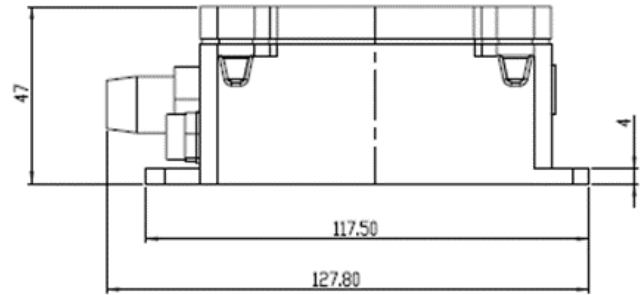
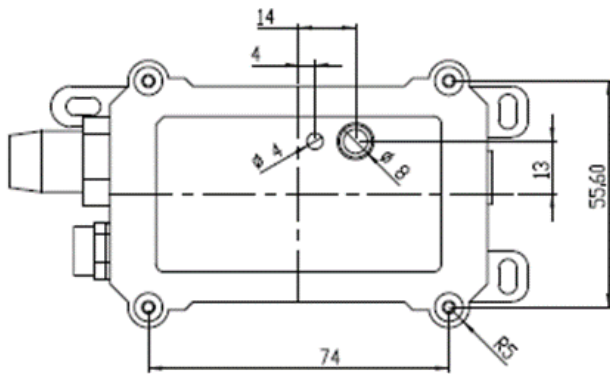

1.11 Cable drawings

- The wire length of WQS sensor products is 5 meters.

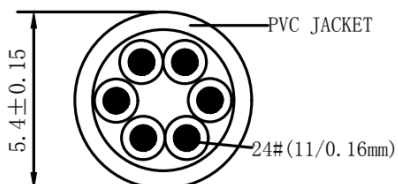
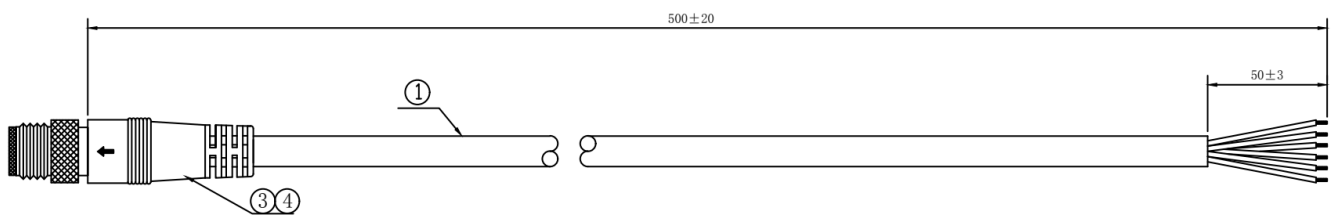

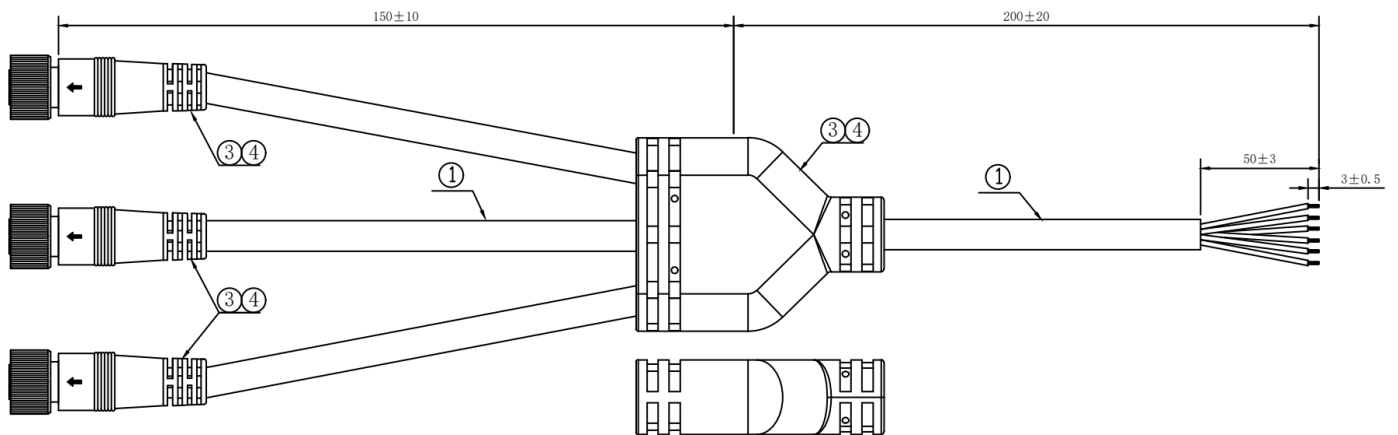

2. Registering WQS-LB/LS with a LoRaWAN Network Server

The WQS-LB/LS can be registered with any LoRaWAN network server. In this documentation, we use The Things Stack as an example, but similar settings may apply to other LoRaWAN network servers.

2.1 Registration information

The WQS-LB/LS is configured in LoRaWAN Class A mode by default. Each WQS-LB/LS is shipped with a unique global registration key that supports OTAA (Over-The-Air-Activation). To use the WQS-LB with a LoRaWAN network, you first need to register the device with the network using the provided registration keys for OTAA support.

The WQS-LB/LS's registration information can be found inside the device package.

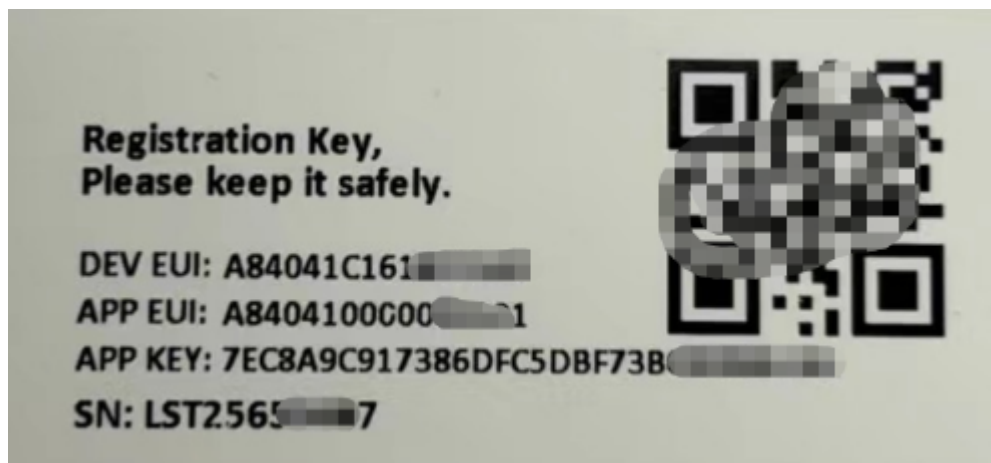

The registration information includes the following:

- DevEUI
- AppEUI
- AppKey

Once registered, if the WQS-LB/LS is within the coverage area of the LoRaWAN network, it can automatically join the network. After successfully joining, the WQS-LB/LS will begin measuring environmental temperature and humidity and will start transmitting sensor data to the LoRaWAN network server. The default uplink transmission interval is 20 minutes.

2.1.1 Registering with The Things Stack

In this section, we will guide you through on how to register the WQS-LB/LS with The Things Stack. If your area has **The Things Stack** community network coverage, you can use it without setting up your own network. If not, you can set up your own LoRaWAN network coverage by using our [LPS8N](#) LoRaWAN gateway.

The typical end-to-end network setup with WQS-LB/LS and LPS8N is shown below:

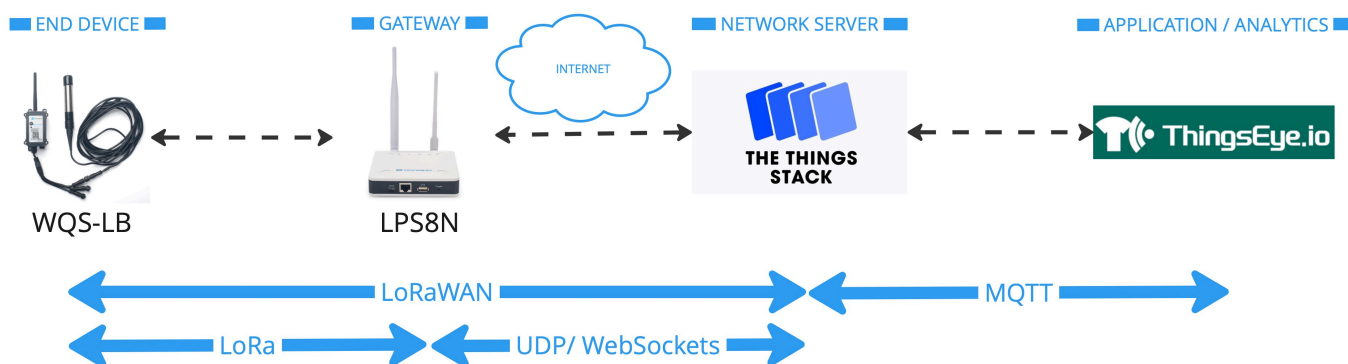

2.1.2 Add WQS-LB/LS to The Things Stack

Currently, WQS-LB/LS only supports manual registration with The Things Stack.

2.1.2.1 Creating an application

Sign up for a free account with [The Things Stack Sandbox](#) if you do not have one yet. Then, create an application as shown in the screenshots below.

Application ID: Provide a unique name to identify your application within The Things Stack, e.g., *dragino-docs*.

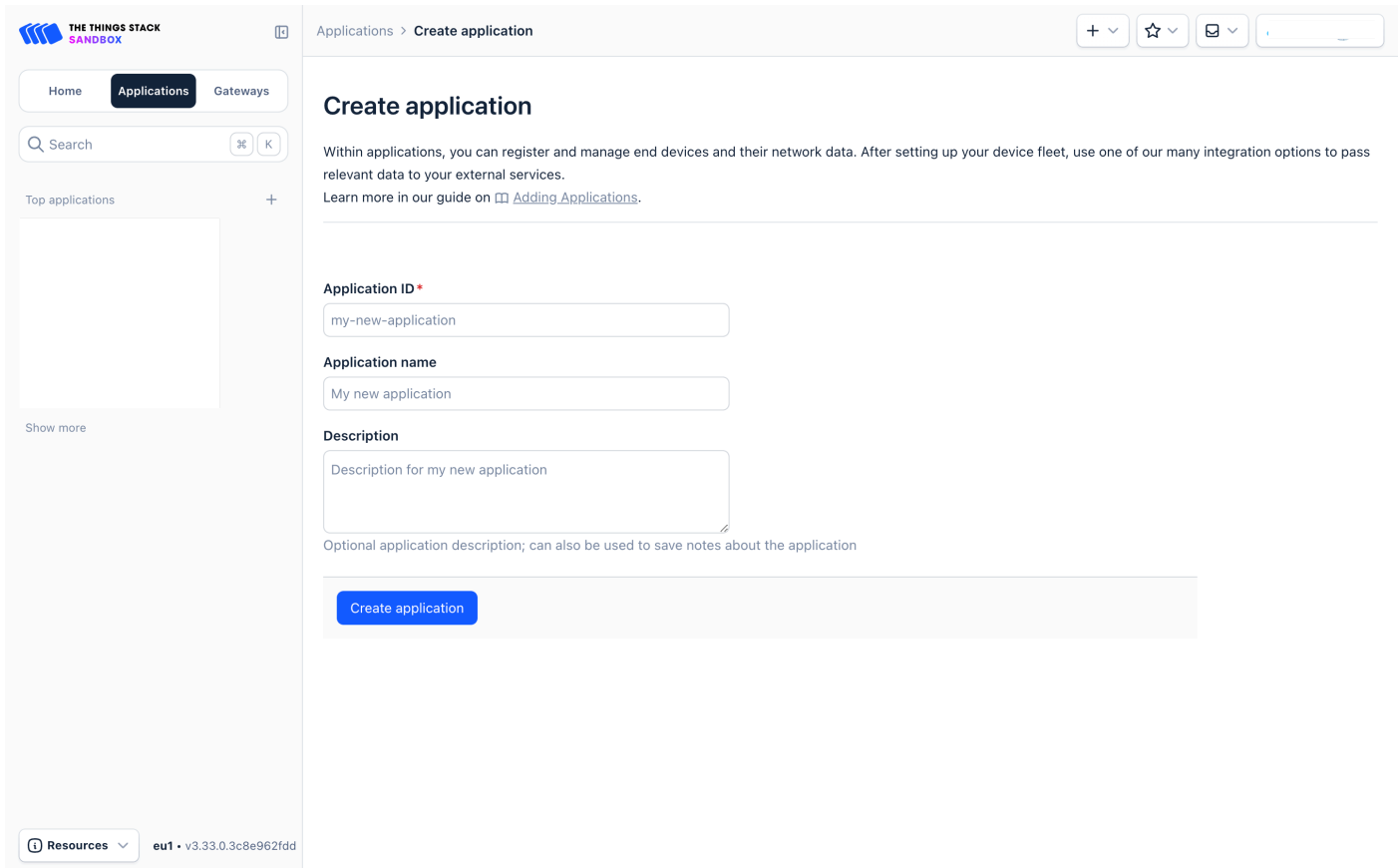

2.1.2.2 Adding manually

You can refer to the screenshots below to register your WQS-LB/LS using The Things Stack's manual option.

On The Things Stack console:

1. Click **Applications**.
2. Click **<your application>**. E.g. dragino-docs
- 3 Click **End devices**.
4. Click **+ Register end device** button.

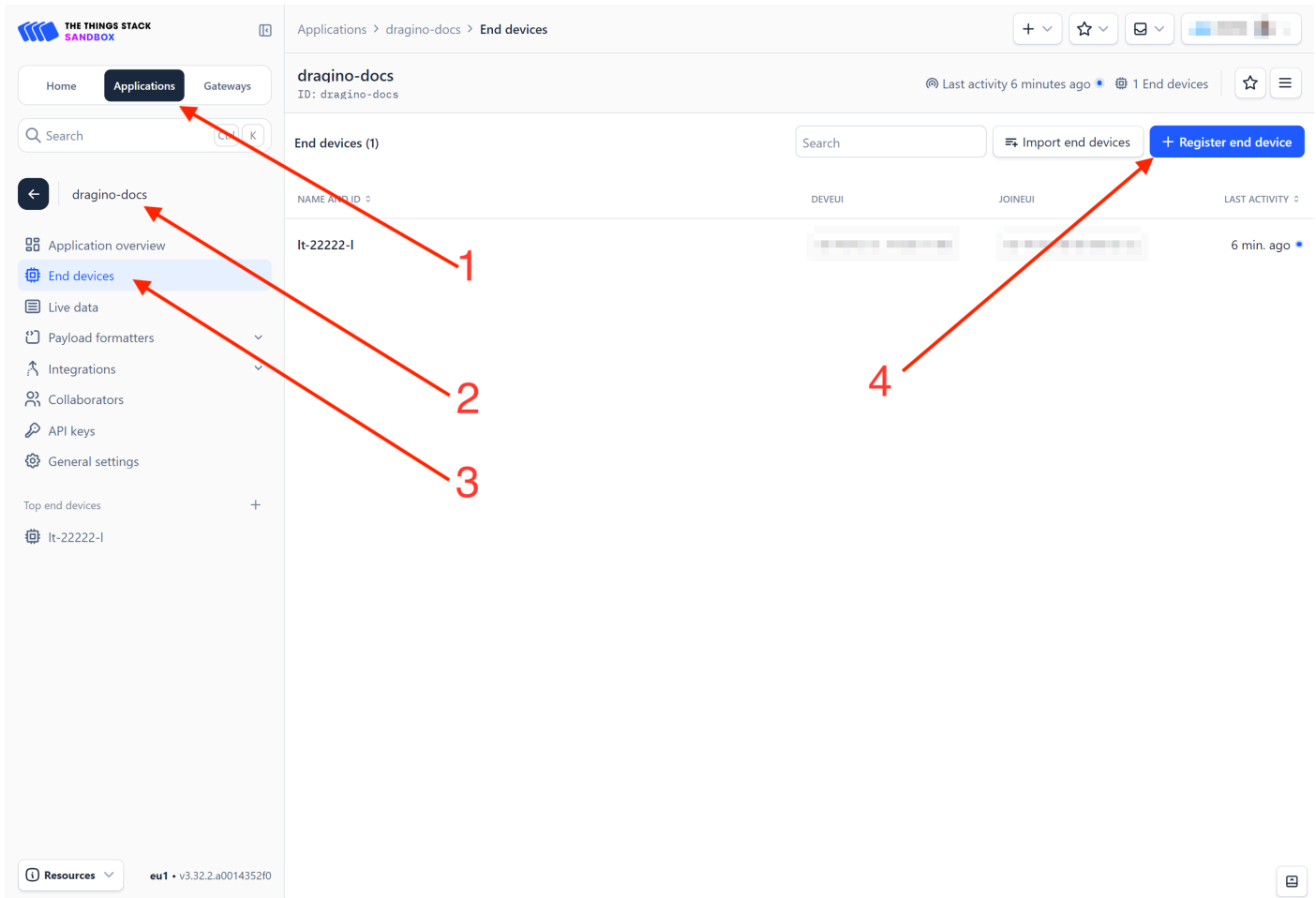

5. Select **Enter end device specifies manually** option.

6. **Frequency plan**: Select the frequency plan that matches your device. E.g.: Europe 863-870 MHz (SF9 for RX2 - recommended).

7. **LoRaWAN version**: LoRaWAN Specification 1.0.3

8. **Regional Parameters version**: You can't change it and it will select automatically.

THE THINGS STACK
SANDBOX

Applications > dragino-docs > End devices > Register end device

Home Applications Gateways

Search [Ctrl] [K]

dragino-docs

- Application overview
- End devices
- Live data
- Payload formatters
- Integrations
- Collaborators
- API keys
- General settings

Top end devices +

- It-22222-1

Resources eu1 • v3.32.2.a0014352f0

Register end device

Does your end device have a LoRaWAN® Device Identification QR Code? Scan it to speed up onboarding.

Scan end device QR code Device registration help

End device type

Input method ⓘ

- Select the end device in the LoRaWAN Device Repository
- Enter end device specifics manually

Frequency plan ⓘ *

Europe 863-870 MHz (SF9 for RX2 - recommended)

LoRaWAN version ⓘ *

LoRaWAN Specification 1.0.3

Regional Parameters version ⓘ *

RP001 Regional Parameters 1.0.3 revision A

[Show advanced activation, LoRaWAN class and cluster settings](#)

Provisioning information

JoinEUI ⓘ *

..... Confirm

To continue, please enter the JoinEUI of the end device so we can determine onboarding options

9. Click on the **Show advanced activation, LoRaWAN class and cluster settings** to expand the section.

10. Select **Over the air activation (OTAA)** option.

11. Select **None (class A only)**.

12. **JoinEUI**: Enter the **AppEUI** of the device (see the registration information sticker) and Click the **Confirm** button.

The screenshot shows the 'Register end device' page in The Things Stack Sandbox. The page is divided into a left sidebar and a main content area. The sidebar contains navigation options like 'Home', 'Applications', and 'Gateways'. The main content area has a breadcrumb trail: 'Applications > dragino-docs > End devices > Register end device'. Below the breadcrumb, there are two radio buttons: 'Select the end device in the LoRaWAN Device repository' (disabled) and 'Enter end device specifics manually' (selected). The 'Enter end device specifics manually' section includes several dropdown menus: 'Frequency plan' (Europe 863-870 MHz (SF9 for RX2 - recommended)), 'LoRaWAN version' (LoRaWAN Specification 1.0.3), and 'Regional Parameters version' (RP001 Regional Parameters 1.0.3 revision A). Below these is a link 'Show advanced activation, LoRaWAN class and cluster settings' with a red arrow labeled '9' pointing to it. The 'Activation mode' section has three radio buttons: 'Over the air activation (OTAA)' (selected, with a red arrow labeled '10' pointing to it), 'Activation by personalization (ABP)', and 'Define multicast group (ABP & Multicast)'. The 'Additional LoRaWAN class capabilities' section has a dropdown menu set to 'None (class A only)' with a red arrow labeled '11' pointing to it. The 'Network defaults' section has a checked checkbox 'Use network's default MAC settings'. The 'Cluster settings' section has an unchecked checkbox 'Skip registration on Join Server'. The 'Provisioning information' section has a 'JoinEUI' input field with a red arrow labeled '12' pointing to it and a 'Confirm' button. Below the input field, there is a note: 'To continue, please enter the JoinEUI of the end device so we can determine onboarding options'. The bottom of the page shows 'Resources' and a version string 'eu1 • v3.32.2.a0014352f0'.

13. **DevEUI:** Enter the DevEUI of the device (see the registration information sticker).
14. **AppKey:** Enter the AppKey of the device (see the registration information sticker).
15. **End device ID:** Enter a name for your end device to uniquely identify it within this application.
16. Click **View registered end device** option.
17. Click **Register end device** button.

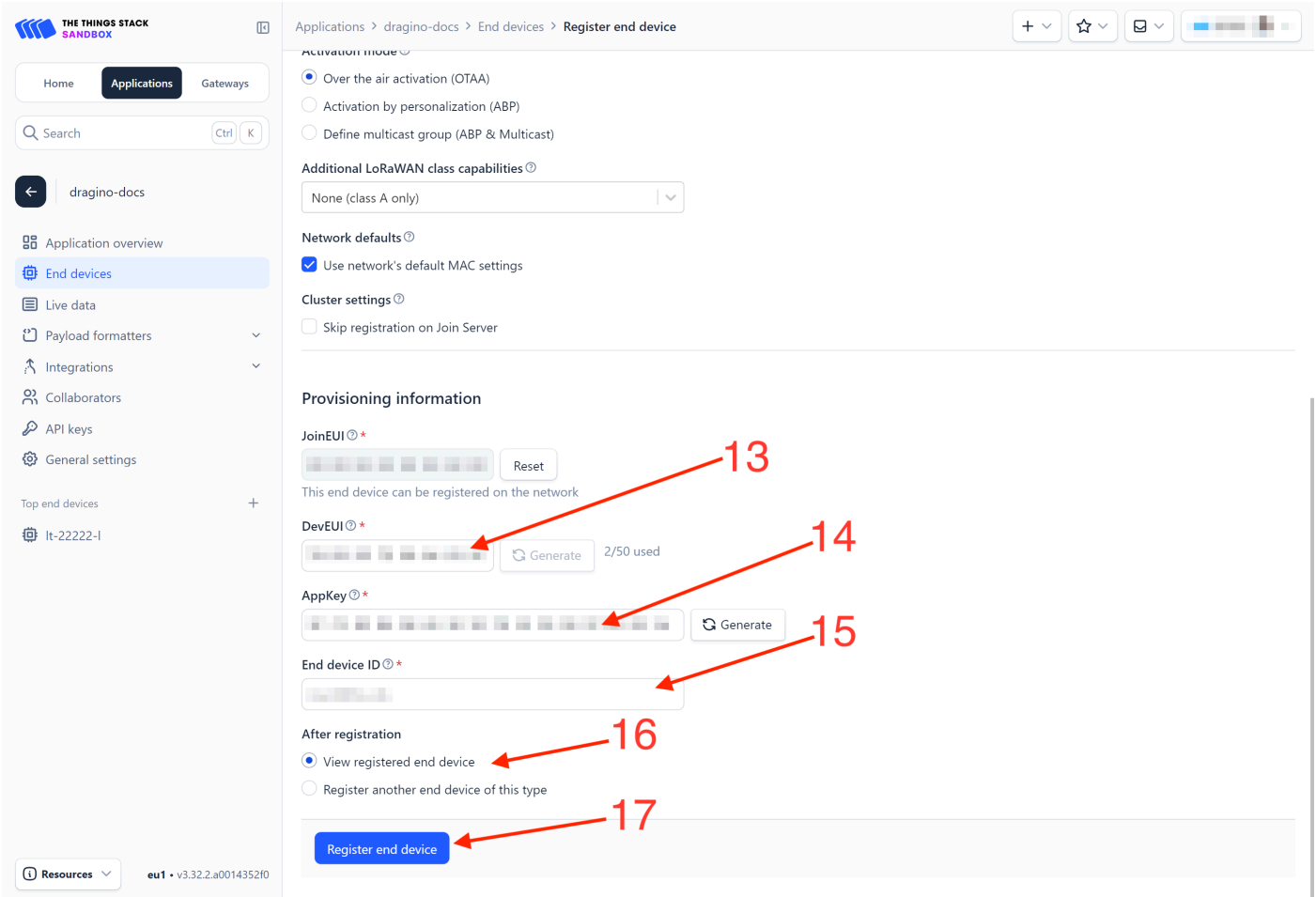

You will be navigated to the **Device overview** page.

2.1.2.3 Power on the WQS-LB/LS

Power on the WQS-LB/LS. It will then join The Things Stack. Once successfully connected, the device will begin uplinking sensor data to The Things Stack, which can be viewed on the Live data panel.

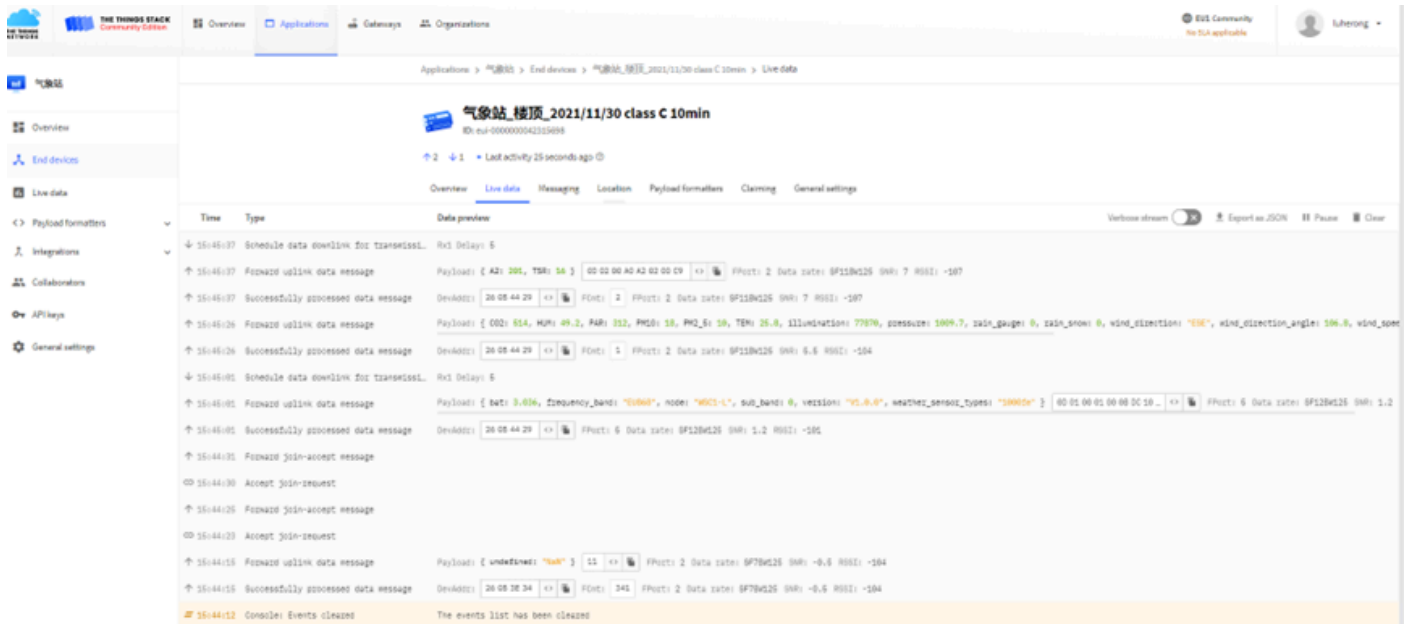

2.1.3 Uplink Decoder in The Things Stack

When the uplink payload arrives in The Things Stack, it is displayed in HEX format, which is not easy to read. You can add the WQS-LB/LS decoder in The Things Stack for easier readability of each sensor reading.

The uplink decoder can be added to the **Payload Formatters** of your device in The Things Stack. Refer to the screenshot below.

1. Click **Uplink** tab.
2. **Formatter type**: Select Custom Javascript formatter.
3. **Formatter code**: Copy the uplink payload formatter code from our [dragino-end-node-decoder GitHub repository](#) and paste it here.
4. Finally, click on the **Save changes** button.

The screenshot shows the 'Payload formatters' configuration page in The Things Stack. The 'Uplink' tab is selected. Under the 'Setup' section, the 'Formatter type*' dropdown is set to 'Custom Javascript formatter'. Below this, the 'Formatter code*' text area contains the following JavaScript code:

```
1 function datalog(i,bytes){
2   var aa= parseFloat((bytes[i]<<24>>16 | bytes[i+1])/1000).toFixed(3);
3   var bb= parseFloat((bytes[i+2]<<24>>16 | bytes[i+3])/1000).toFixed(3);
4   var cc= parseFloat((bytes[i+4]<<24>>16 | bytes[i+5])/1000).toFixed(3);
5   var string='['+ aa +'],'+ '('+ bb +'),' + '('+ cc +' )'+',';
6   return string;
7 }
8
9 function Decoder(bytes, port) {
10  if(port==0x02)
11  {
12    var decode = {};
13    decode.BatV=(bytes[0]<<8 | bytes[1])/1000;
14    var mod=(bytes[2]>>2)&0x07;
15    if(mod==1)
16    {
17      decode.vib_count=(bytes[3]<<8 | bytes[4]<<8 | bytes[5]<<8 | bytes[6])>>>0;
18      decode.work_min=(bytes[7]<<8 | bytes[8]<<8 | bytes[9]<<8 | bytes[10])>>>0;
19    }
20    else if(mod==2)
21    {
22      decode.vib_count=(bytes[2]<<8 | bytes[4]<<8 | bytes[5]<<8 | bytes[6])>>>0;
```

2.2 Uplink payload

Uplink payloads include two types: Valid Sensor Values and other status/control commands.

- **Valid Sensor Values**: Use FPort=2.
- **Other status/control commands**: Use FPort other than 2.

2.2.1 Uplink FPort=5, Device status

Uplink the device configuration with FPort=5. Once the WQS-LB/LS joins the network, it will send this message to the server. After the first uplink, the WQS-LB/LS will transmit the **device status** every 12 hours.

Users can also use the downlink command (0x2601) to request the WQS-LB/LS to resend this uplink.

Size(bytes)	1	2	1	1	2
Value	Sensor Model	Firmware Version	Frequency Band	Sub-band	BAT

The screenshot shows a data stream interface with a 'Data preview' section. The payload for a 'Forward uplink data message' is displayed as a JSON object: { BAT: 3.528, FIRMWARE_VERSION: "1.0.0", FREQUENCY_BAND: "EU868", SENSOR_MODEL: "WQS01-LB", SUB_BAND: 0 }. The corresponding hex value 3C 01 00 01 00 0D C8 is shown in a box on the right. The interface also includes controls for 'Verbose stream', 'Export as JSON', 'Pause', and 'Clear'.

Example payload (FPort=5): 3C 01 00 01 00 0D C8

Sensor Model: 1 byte

For WQS-LB, this value is 0x3C.

Firmware Version: 2 bytes

0x0100, Means: v1.0.0 version.

Frequency Band: 1 byte

- 0x01: EU868
- 0x02: US915
- 0x03: IN865
- 0x04: AU915
- 0x05: KZ865
- 0x06: RU864
- 0x07: AS923
- 0x08: AS923-1
- 0x09: AS923-2
- 0x0a: AS923-3
- 0x0b: CN470
- 0x0c: EU433
- 0x0d: KR920
- 0x0e: MA869

Sub-Band: 1 byte

value 0x00 ~ 0x08 (only for CN470, AU915,US915. Others are 0x00)

BAT: 2 bytes

shows the battery voltage for WQS-LB MCU.

Ex1: $0x0DC8/1000 = 3.528 \text{ V}$

2.2.3 Uplink FPort=2, Real time sensor value

The WQS-LB/LS will send this uplink after the Device Config uplink once it successfully joins the LoRaWAN network. It will then periodically send this uplink. The default interval is 20 minutes, but this [can be changed](#).

The uplink uses **FPort=2** and, by default, sends one uplink every 20 minutes.

The uplink length is dynamic and depends on the types of weather sensors connected. The uplink payload is composed of sensor segments, as shown below:

Size(bytes)	2	2	1	2	2	2	2	2	2	2	2	2
Value	BAT	temperature DS18B20	flag and Sensor Identifier	turbidity	dissolved oxygen	ORP	ECK10	ECK10_temp	ECK1	ECK1_temp	PH	PH_temp

ir: 26 0B 4F 6D Payload: { BatV: 3.252, ORP: 2, PH: 7.34, PH_Temp: 27.3, i_flag: 0, temp_DS18B20: "327.60", turbidity: 251 } 0C B4 0C CC 29 09 CE 00 02 DE 01 11... FPort

Payload Example (FPort=2): 0CB4 0CCC 29 09CE 0002 02DE 0111

The WQS-LB/LS is connected to three sensors, PH, ORP, and turbidity.

BAT: 2 bytes

Shows the battery voltage for WQS-LB/LS MCU.

Ex1: $0x0CB4/1000 = 3.252 \text{ V}$

Temperature: 2 bytes

This is the data of the external DS18B20 temperature sensor.

If the DS18B12 sensor is not connected, it will display: $0CCC/10 = 327.60^\circ\text{C}$

Flag and Sensor Identifier: 1 byte (Version 1.3.1 is 2 bytes)

The Flag and Sensor Identifier uses a hexadecimal byte, which becomes 8 digits when converted to binary.

Example:

$0x29 \text{ (H)} = 0010 \ 1001 \text{ (B)}$

00 indicates the interrupt identifier.

The remaining six digits represent the identifiers of the turbidity, dissolved oxygen, ORP, ECK10, ECK1, and pH sensors, in that order.

For example, **101001** means that the WQS-LB/LS has three sensors connected: turbidity, ORP, and pH.

Sensor data: each 2 bytes, total 6 bytes

turbidity: 0x09CE/10=251

ORP: 0x0002=2

pH: 0x02DE/100=7.34

pH_temp=0x0111/10=27.3

2.3 Uplink FPort=3, Datalog

Datalog Feature is to ensure IoT Server can get all sampling data from Sensor even if the LoRaWAN network is down. For each sampling, WQS-LB/LS will store the reading for future retrieving purposes.

2.3.1 How datalog works

WQS-LB/LS will wait for ACK for every uplink, when there is no LoRaWAN network, WQS-LB/LS will mark these records with non-ack messages and store the sensor data, and it will send all messages (10s interval) after the network recovery.

- a) WQS-LB will do an ACK check for data records sending to make sure every data arrive server.
- b) WQS-LB will send data in **CONFIRMED Mode**, but WQS-LB/LS won't re-transmit the packet if it doesn't get ACK, it will just mark it as a NONE-ACK message. In a future uplink if WQS-LB/LS gets a ACK, WQS-LB will consider there is a network connection and resend all NONE-ACK messages.

2.3.2 Enable Datalog

User need to make sure below two settings are enable to use datalog;

- **SYNCMOD=1(Default)** to enable sync time via LoRaWAN MAC command, click here ([AT+SYNCMOD](#)) for detailed instructions.
- **PNACKMD=1** to enable datalog feature, click here ([AT+PNACKMD](#)) for detailed instructions.

Once WQS-LB/LS Joined LoRaWAN network, it will send the MAC command (DeviceTimeReq) and the server will reply with (DeviceTimeAns) to send the current time to WQS-LB. If WQS-LB fails to get the time from the server, WQS-LB will use the internal time and wait for next time request (AT+SYNCTDC to set the time request period, default is 10 days).

Note: LoRaWAN Server need to support LoRaWAN v1.0.3(MAC v1.0.3) or higher to support this MAC command feature, Chirpstack,TTN V3 v3 and loriot support but TTN V3 v2 doesn't support. If server doesn't support this command, it will through away uplink packet with this command, so user will lose the packet with time request for TTN V3 v2 if SYNCMOD=1.

2.3.3 Unix TimeStamp

WQS-LB/LS uses Unix TimeStamp format based on

Size (bytes)	4	1
DeviceTimeAns Payload	32-bit unsigned integer : Seconds since epoch*	8bits unsigned integer: fractional-second in $\frac{1}{2}^8$ second steps

Figure 10 : DeviceTimeAns payload format

User can get this time from link: <https://www.epochconverter.com/> :

Below is the converter example

The screenshot shows two web interfaces. On the left, EpochConverter displays the current Unix epoch time as 1611889418. On the right, Code Beautify's 'Decimal to Hex' converter shows the decimal value 1611889405 being converted to the hexadecimal value 60137afd. A red arrow points from the epoch time in the EpochConverter interface to the decimal input field in the Code Beautify interface.

So, we can use AT+TIMESTAMP=1611889405 or downlink 3060137afd00 to set the current time 2021 – Jan -- 29 Friday 03:03:25

2.3.4 Datalog Uplink payload (FPORT=3)

The Datalog uplinks will use below payload format.

Retrieval data payload:

Note: WQS-LB/LS can be equipped with 3 optional sensors. The datalog is sorted in the following order.

Size(bytes)	2	2	2	2	2	2	4
Value	turbidity(Options)	dissolved oxygen(Options)	ORP(Options)	ECK10(Options)	ECK1(Options)	PH(Options)	Unix Timestamp

Example:

The WQS-LB/LS will uplink this payload:



048B013E03889367D39699

Where the first 10 bytes is for the first entry:

048B013E03889367D39699

dissolved oxygen=0x048B/100=11.63

ECK1=0x013E=318

PH=0x0388/100=9.04

Unix time is 0x67D39699=1741919897s=25/3/14 02:38:17

No ACK Message: 1: This message means this payload is fromn Uplink Message which doesn't get ACK from the server before (for **PNACKMD=1** feature)

Poll Message Flag: 1: This message is a poll message reply.

- Poll Message Flag is set to 1.
- Each data entry is 11 bytes, to save airtime and battery, devices will send max bytes according to the current DR and Frequency bands.

For example, in US915 band, the max payload for different DR is:

- a) **DR0:** max is 11 bytes so one entry of data
- b) **DR1:** max is 53 bytes so devices will upload 4 entries of data (total 44 bytes)
- c) **DR2:** total payload includes 11 entries of data
- d) **DR3:** total payload includes 22 entries of data.

If devise doesn't have any data in the polling time. Device will uplink 11 bytes of 0

2.4 Integrating data with IoT platforms

The WQS-LB/LS sensor data can be integrated with other IoT platforms for better visualizing and analyzing the data. In this section, we will show you how to integrate sensor data from The Things Stack with some popular IoT platforms.

2.4.1 Integrate and show data on ThingsEye

The Things Stack application supports integration with ThingsEye.io. Once integrated, ThingsEye.io acts as an MQTT client for The Things Stack MQTT broker, allowing it to subscribe to upstream traffic and publish downlink traffic.

2.4.1.1 Configuring The Things Stack

We use The Things Stack Sandbox in this example:

- In **The Things Stack Sandbox**, go to the **Application** for the WQS-LB/LS you added.
- Select **MQTT** under **Integrations** in the left menu.
- In the **Connection information** section, under **Connection credentials**, The Things Stack displays an auto-generated **username**. You can use it or provide a new one.
- Click the **Generate new API key** button to generate a password. You can view it by clicking on the **visibility toggle/eye** icon. The API key works as the password.

i The username and password (API key) you created here are required in the next section.

The screenshot shows the 'MQTT' configuration page for an application named 'dragino-docs' in the 'The Things Stack Sandbox'. The page is divided into several sections:

- MQTT**: A descriptive paragraph explaining that MQTT is a publish/subscribe messaging protocol for IoT and that a new API key must be created to function as a connection password.
- Further resources**: A link to the 'MQTT server | Official MQTT website'.
- Connection information**:
 - MQTT server host**:
 - Public address: eu1.cloud.thethings.network:1883
 - Public TLS address: eu1.cloud.thethings.network:8883
 - Connection credentials**:
 - Username: A dropdown menu showing a generated username.
 - Password: A text input field containing a generated API key, with a visibility toggle (eye icon) on the right.

The left sidebar contains navigation options: Home, Applications (selected), Gateways, Search, and a list of integrations including MQTT (highlighted), Webhooks, Storage Integration, AWS IoT, Azure IoT, LoRa Cloud, Collaborators, API keys, and General settings. The bottom of the sidebar shows 'Resources' and the application ID 'eu1 • v3.32.2.a0014352f0'.

2.4.1.2 Configuring ThingsEye.io

The ThingsEye.io IoT platform is not open for self-registration at the moment. If you are interested in testing the platform, please send your project information to admin@thingseye.io, and we will create an account for you.

- Login to your [ThingsEye.io](https://thingseye.io)  account.
- Under the **Integrations center**, click **Integrations**.
- Click the **Add integration** button (the button with the + symbol).

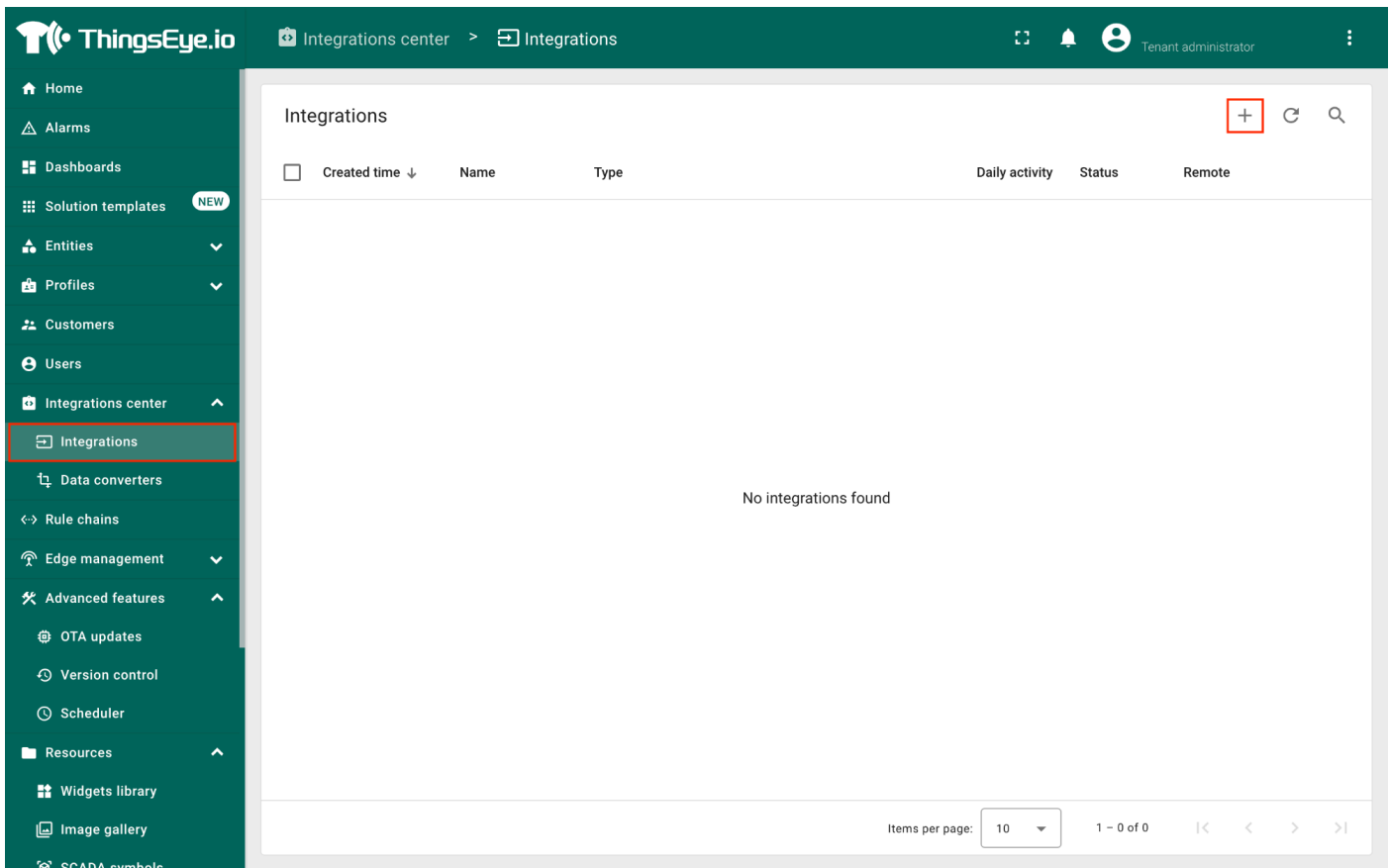

On the **Add integration** window, configure the following:

Basic settings:

- Select **The Things Stack Community** from the **Integration type** list.
- Enter a suitable name for your integration in the **Name** text box or keep the default name.
- Ensure the following options are turned on.
 - Enable integration
 - Debug mode
 - Allow create devices or assets
- Click the **Next** button. you will be navigated to the **Uplink data converter** tab.

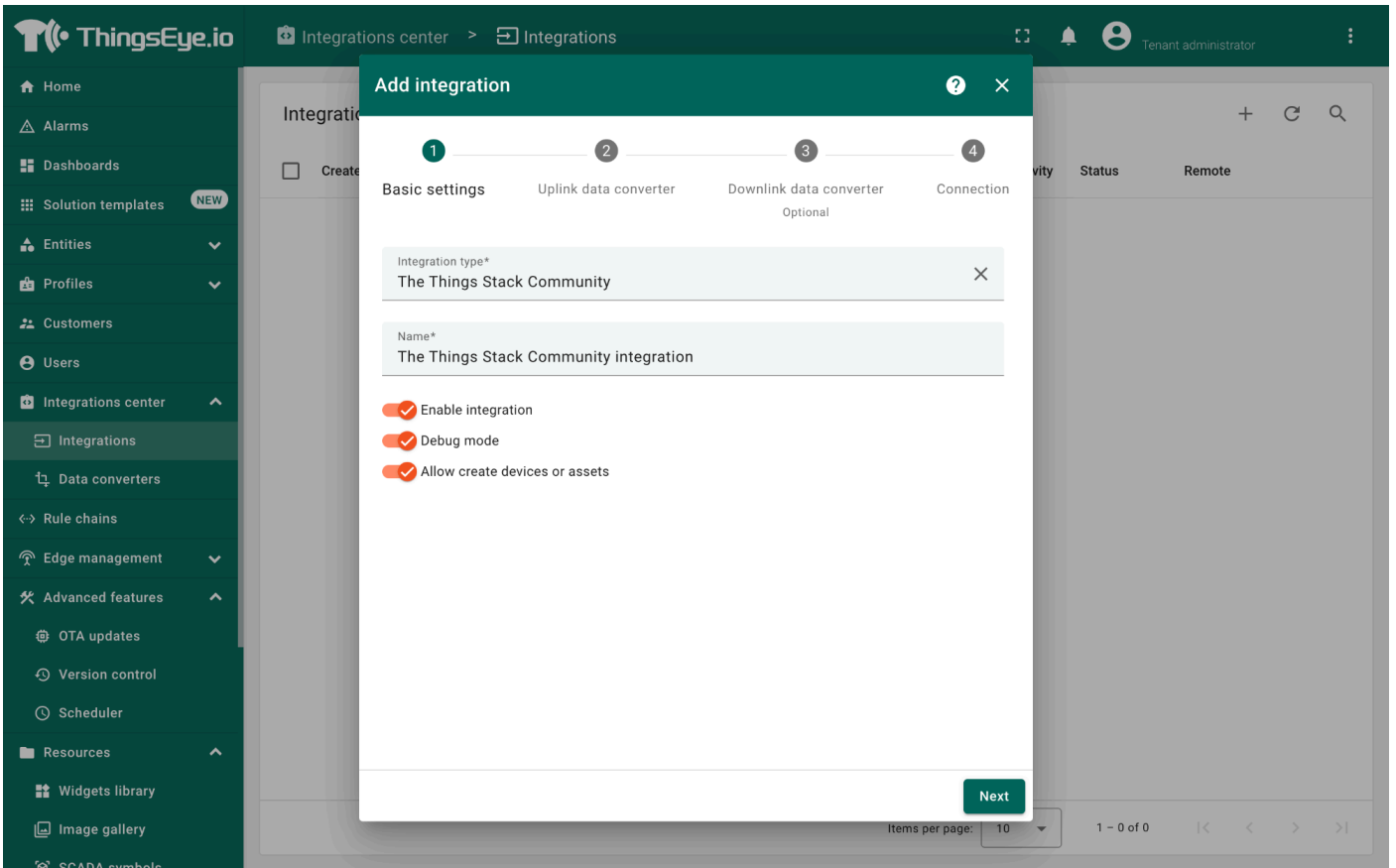

Uplink data converter:

- Click the **Create new** button if it is not selected by default.
- Enter a suitable name for the uplink data converter in the **Name** text box or keep the default name.
- Click the **JavaScript** button.
- Paste the uplink decoder function into the text area (first, delete the default code). The demo uplink decoder function can be found [here](#).
- Click the **Next** button. You will be navigated to the **Downlink data converter** tab.

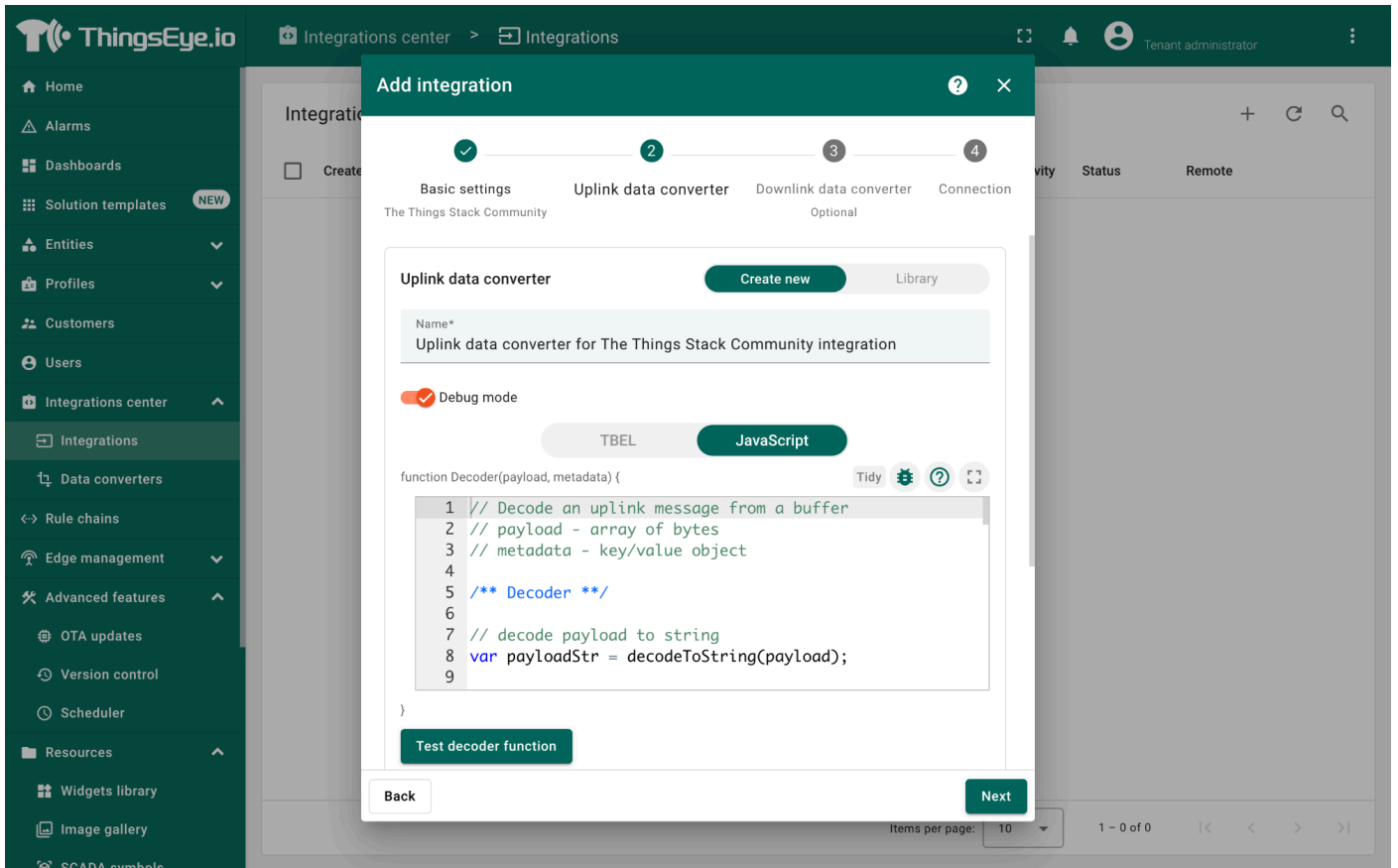

Downlink data converter (this is an optional step):

- Click the **Create new** button if it is not selected by default.
- Enter a suitable name for the downlink data converter in the **Name** text box or keep the default name.
- Click the **JavaScript** button.
- Paste the downlink decoder function into the text area (first, delete the default code). The demo downlink decoder function can be found [here](#).
- Click the **Next** button. You will be navigated to the **Connection** tab.

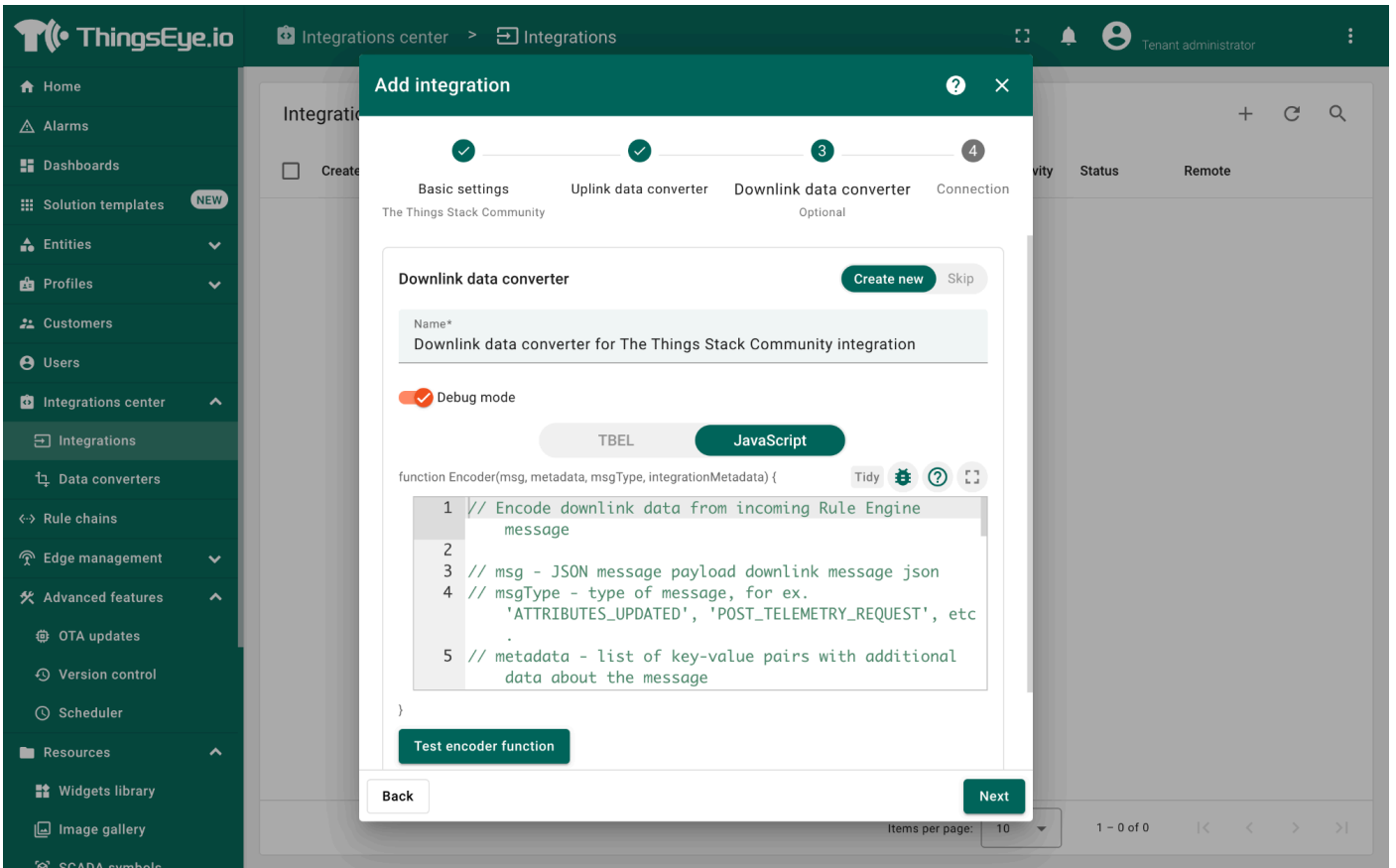

Connection:

- Choose **Region** from the **Host type**.
- Enter the **cluster** of your **The Things Stack** in the **Region** textbox. You can find the cluster in the url (e.g., <https://eu1.cloud.thethings.network/...>).
- Enter the **Username** and **Password** of the MQTT integration in the **Credentials** section. The **username** and **password** can be found on the MQTT integration page of your The Things Stack account (see **3.5.1 Configuring The Things Stack**).
- Click the **Check connection** button to test the connection. If the connection is successful, you will see the message saying **Connected**.

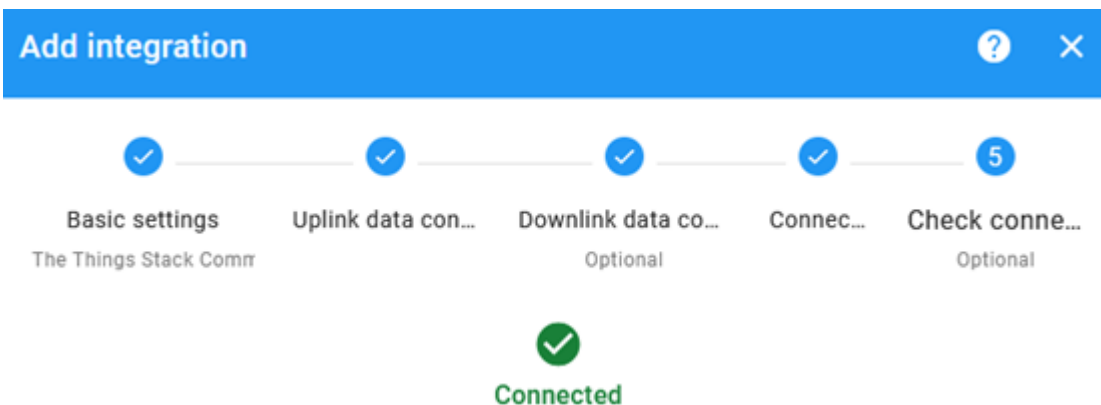

- Click the **Add** button.

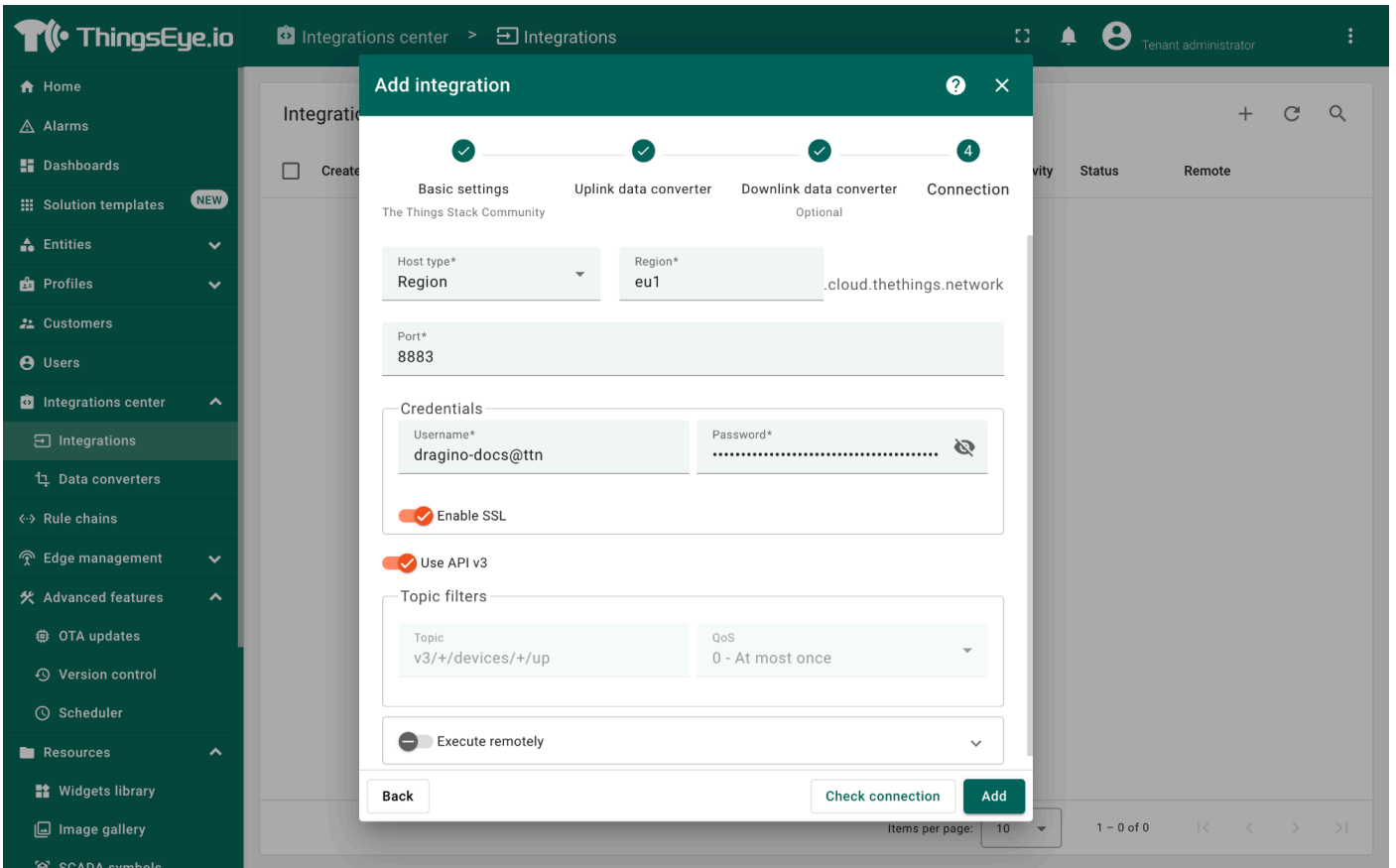

Your integration has been added to the **Integrations** list and will be displayed on the **Integrations** page. Check whether the status is shown as **Active**. If not, review your configuration settings and correct any errors.

The screenshot displays the 'Integrations center' in the ThingsEye.io interface. The left sidebar contains a navigation menu with items such as Home, Alarms, Dashboards, Solution templates (marked as NEW), Entities, Profiles, Customers, Users, Integrations center (selected), Integrations, Data converters, Rule chains, Edge management, Advanced features, OTA updates, Version control, Scheduler, Resources, Widgets library, Image gallery, SCADA symbols, Resources library, and Notification center. The main content area is titled 'Integrations' and features a table with the following columns: Created time, Name, Type, Daily activity, Status, and Remote. A single integration is listed with a creation time of 2024-10-31 10:47:24, named 'The Things Stack Community integration', and is currently 'Active'. The interface also includes a search bar, a refresh button, and a pagination control at the bottom right showing 'Items per page: 10' and '1 - 1 of 1'.

Created time ↓	Name	Type	Daily activity	Status	Remote
2024-10-31 10:47:24	The Things Stack Community integration	The Things Stack Community		Active	<input type="checkbox"/>

2.4.1.3 Viewing integration details

Click on your integration from the list. The **Integration details** window will appear with the **Details** tab selected. The **Details** tab shows all the settings you have provided for this integration.

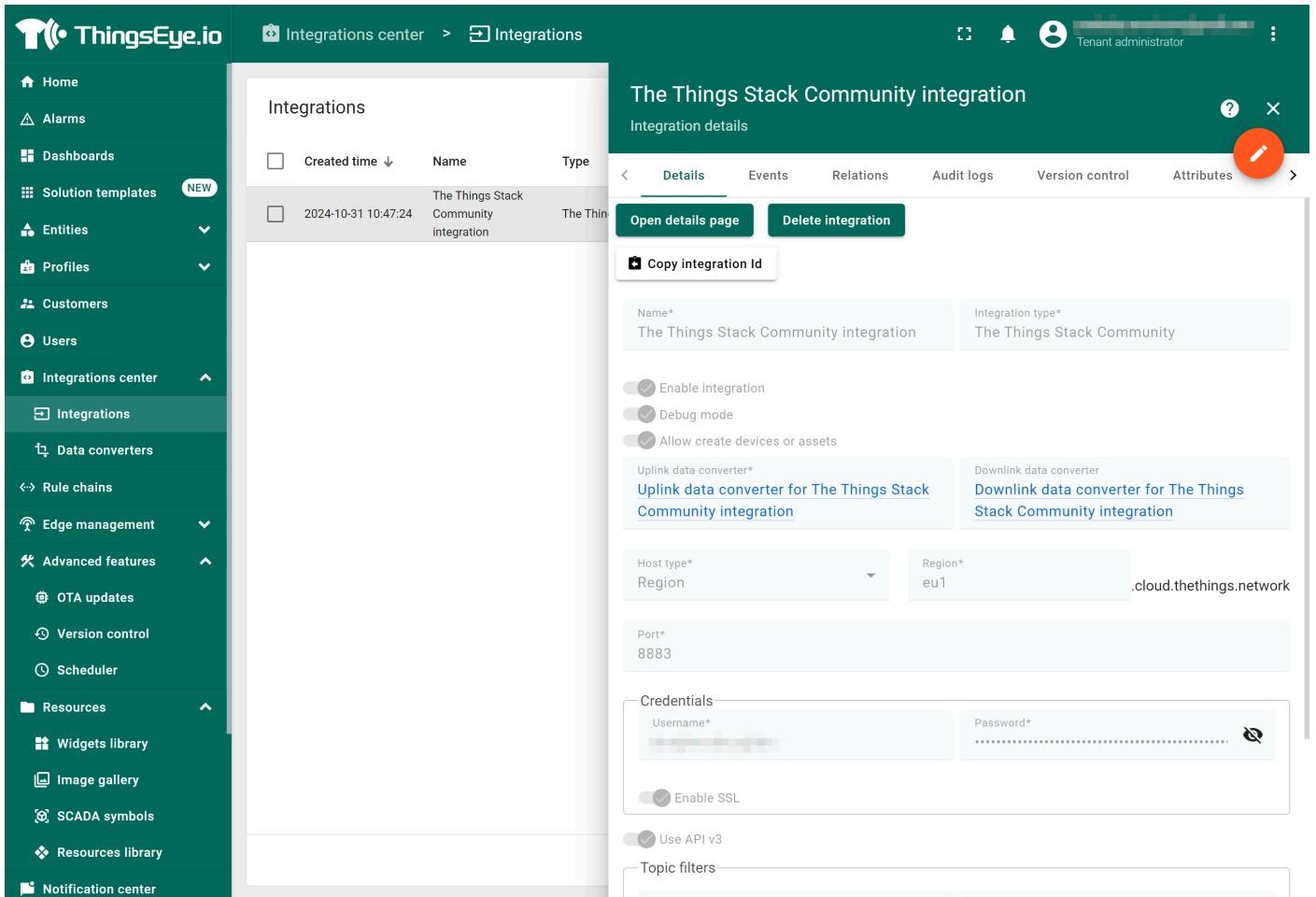

If you want to edit the settings you have provided, click on the **Toggle edit mode** button. Once you have done click on the **Apply changes** button.

[See also ThingsEye documentation](#).

2.4.1.4 Viewing events

The **Events** tab displays all the uplink messages from the WQS-LB/LS.

- Select **Debug** from the **Event type** dropdown.
- Select the **time frame** from the **time window**.

The screenshot shows the 'Integrations center' in ThingsEye.io. The main view is 'The Things Stack Community integration' with the 'Events' tab selected. A red box highlights the 'Event type' dropdown set to 'Debug' and the 'last 12 hours' filter. The table below shows 12 events, all with 'Uplink' type and 'OK' status.

Event time ↓	Server	Type	Message	Status	Error
2024-11-09 21:56:58.451	iZgw89mbkak3w90civ0w7zZ	Uplink	...	OK	
2024-11-09 21:46:58.487	iZgw89mbkak3w90civ0w7zZ	Uplink	...	OK	
2024-11-09 21:36:58.525	iZgw89mbkak3w90civ0w7zZ	Uplink	...	OK	
2024-11-09 21:26:58.553	iZgw89mbkak3w90civ0w7zZ	Uplink	...	OK	
2024-11-09 21:16:58.575	iZgw89mbkak3w90civ0w7zZ	Uplink	...	OK	
2024-11-09 21:06:58.578	iZgw89mbkak3w90civ0w7zZ	Uplink	...	OK	
2024-11-09 20:56:58.617	iZgw89mbkak3w90civ0w7zZ	Uplink	...	OK	
2024-11-09 20:46:58.640	iZgw89mbkak3w90civ0w7zZ	Uplink	...	OK	
2024-11-09 20:36:58.656	iZgw89mbkak3w90civ0w7zZ	Uplink	...	OK	
2024-11-09 20:26:58.698	iZgw89mbkak3w90civ0w7zZ	Uplink	...	OK	

- To view the **JSON payload** of a message, click on the **three dots (...)** in the Message column of the desired message.

```

"correlation_ids": [{"gs:uplink:01JF0VN85/13X4Z5/1ZV2MQM1C"}],
"received_at": "2024-12-13T20:34:14.007746448Z",
"uplink_message": {
  "session_key_id": "AZO+3hLhoLTaPhQP6ozoZA==",
  "f_port": 2,
  "f_cnt": 40,
  "frm_payload": "CTAMzBED+wKL",
  "decoded_payload": {
    "BatV": 2.352,
    "PH": 6.51,
    "dissolved_oxygen": 10.19,
    "i_flag": 0,
    "temp_DS18B20": "327.60"
  },
  "rx_metadata": [{
    "gateway_ids": {
      "gateway_id": "11:8",
      "eui": "A840:1866"
    },
    "time": "2024-12-13T20:34:13.685230Z",
    "timestamp": 3668838876,
    "rssi": -102,
    "channel_rssi": -102,
    "snr": 6.5,
    "uplink_token": "ChUKEwoHMTEzLTg20BIIqEBBG35eGGYQ3J041Q0aDAjFtPK6BhD7ltX8AiDghtq+4784",
    "channel_index": 5,
    "received_at": "2024-12-13T20:34:13.683155055Z"
  }], {
    "gateway_ids": {
      "gateway_id": "eui-b8ea26f",
      "eui": "B8EA2:D28"
    },
    "time": "2024-12-13T20:34:13.679036Z",
    "timestamp": 1997397654,
    "rssi": -113,
    "channel_rssi": -113,
    "snr": -1,
    "frequency_offset": "-320",
    "uplink_token": "CiIKIAoUZxVpLWI4ZWEyNmZkZmUyZDVkMjgSCLjqJv3+LV0oEJa9t7gHGgwIxbTyugYQ1fDdggMg8P",
    "channel_index": 5,
    "received_at": "2024-12-13T20:34:13.696469725Z"
  }],
"settings": {
  "data_rate": {

```

Close

2.4.1.5 Deleting an integration

If you want to delete an integration, click the **Delete integration** button on the Integrations page.

2.4.1.6 Creating a dashboard

The following image shows a dashboard created using ThingsEye to display sensor data on widgets, allowing users to analyze and visualize the data.

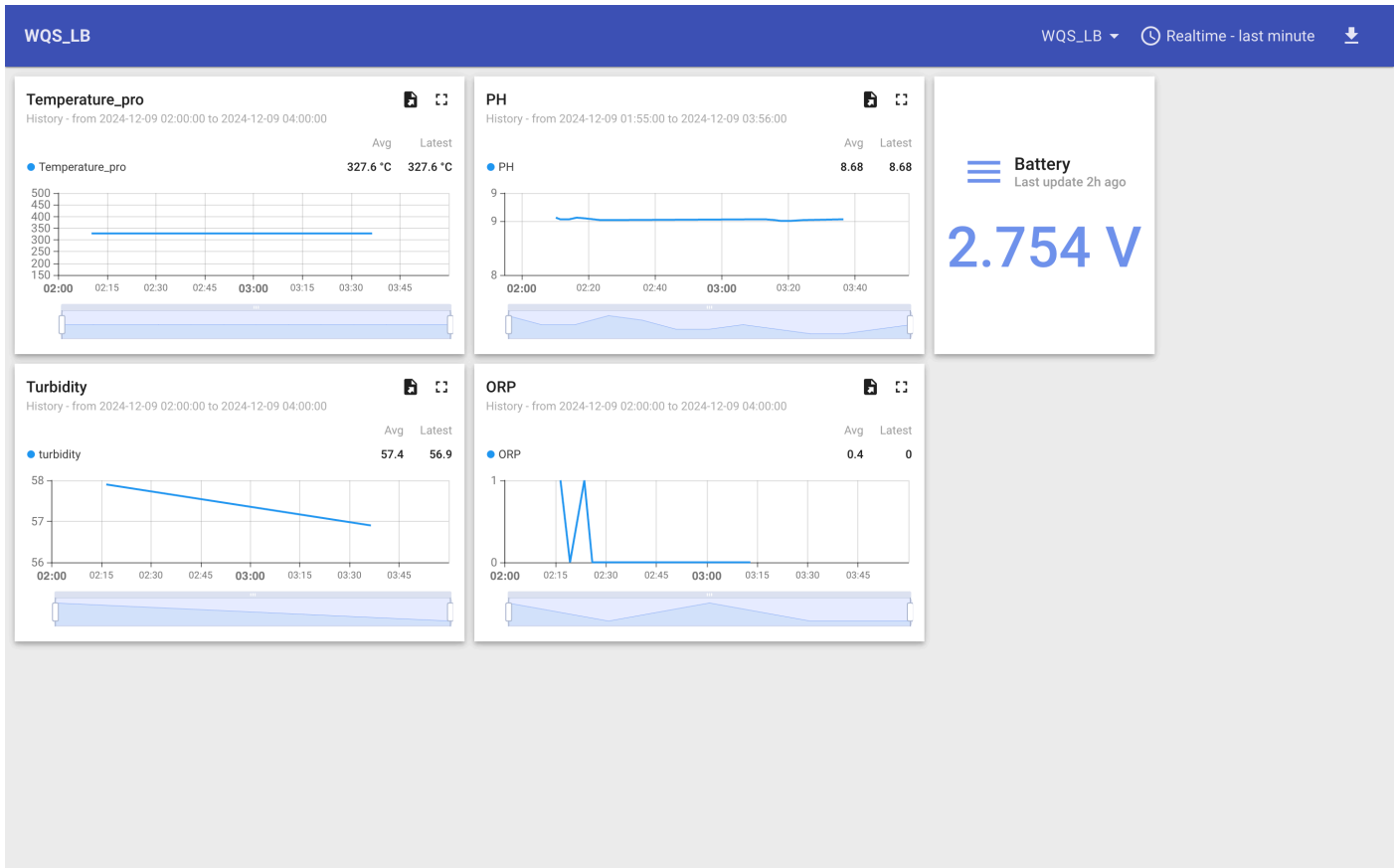

2.4.2 Integrate and show data on TagoIO

TagoIO is a scalable IoT platform that allows easily build scalable IoT solutions. **The Things Stack** application supports integration with **TagoIO** using **webhooks**.

- Ensure that WQS-LB/LS is properly connected to The Things Stack.
- Then configure your The Things Stack application to forward data to TagoIO by adding an integration with webhooks.
- In The Things Stack console, navigate to **Applications** → **<your application>** → **Integrations** → **Webhooks** → **+ Add webhook**.

Step 1: Be sure that your device is programmed and properly connected to the LoRaWAN network.

Step 2: Configure your Application to forward data to Datacake you will need to add integration. Go to TTN V3 Console --> Applications --> Integrations --> Add Integrations.

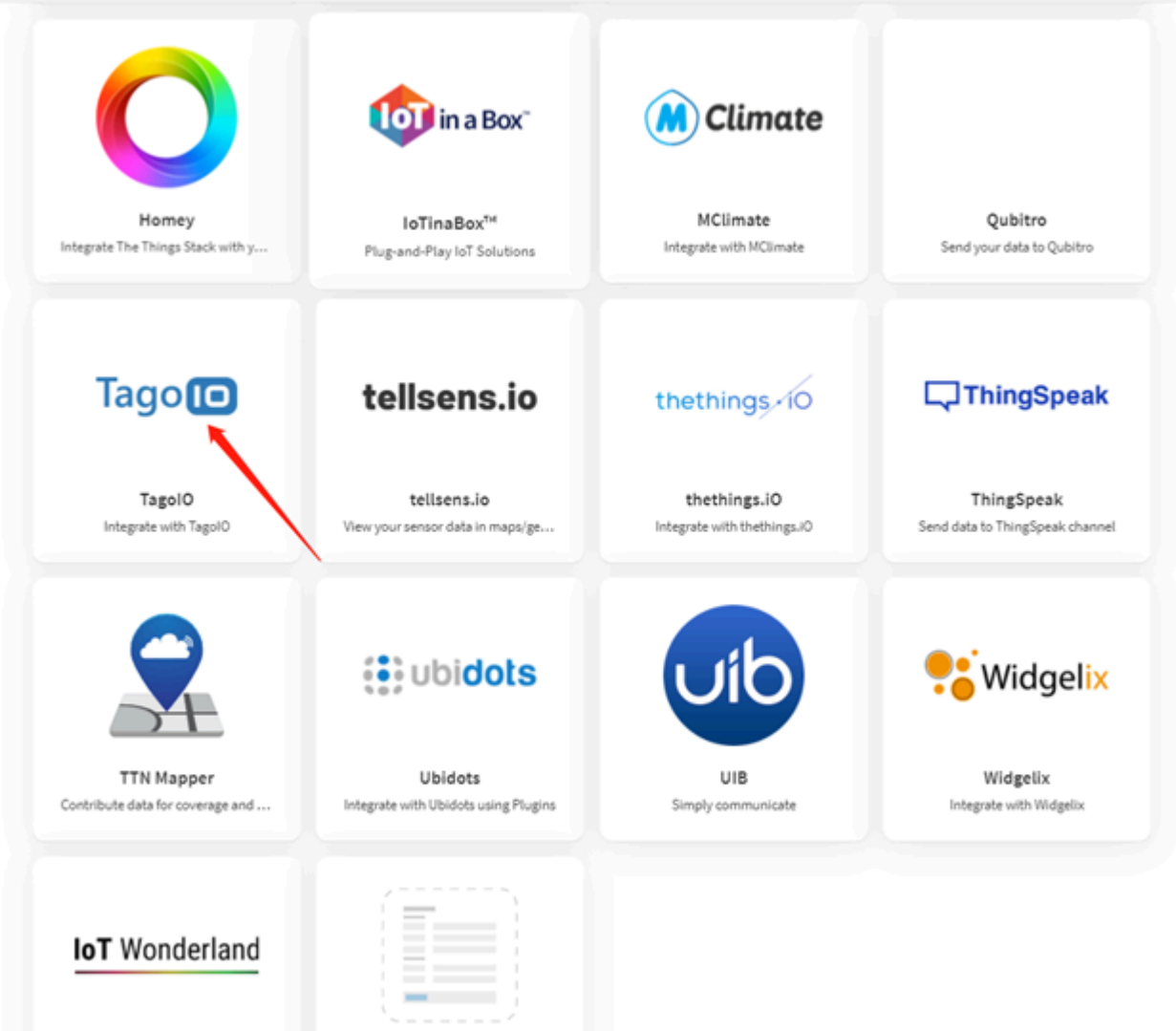

In the **Setup webhook for TagoIO** page:

- **Webhook ID** - enter a name to identify your webhook.
- **Authorization**: Paste the authorization code copied from the TagoIO.
- Click **Create TagoIO webhook** button.

THE THINGS STACK SANDBOX

Applications > dragino-docs > Webhooks > Add > TagoIO

dragino-docs ID: dragino-docs Last activity 6 days ago 1 End devices

Setup webhook for TagoIO

Integrate with TagoIO [About TagoIO |](#)

Webhook ID*

Authorization*

TagoIO Authorization

[Create TagoIO webhook](#)

Resources eu1 • v3.33.0.3c8e962fdd

Authorization:

TagoIO | dragino

Devices [Authorization](#) [Add Device](#)

Devices are the link between external things and the buckets in your account. [Read more](#)

Name	Last Input	Last Output	Connector	Network	Active	Bucket linked	Created at
物联网声控	3 minutes ago	Never	Custom The Things Industries	LoRaWAN TT/TTN v3	Yes	物联网声控	3 months ago
LD003A_声门	22 minutes ago	Never	Custom The Things Industries	LoRaWAN TT/TTN v3	Yes	LD003A_声门	3 months ago
气象站	3 minutes ago	Never	Custom The Things Industries	LoRaWAN TT/TTN v3	Yes	气象站	3 months ago

DASHBOARDS

- LD003A_back door
- LMDK200
- Weather station

In TagoIO console (<https://admin.tago.io/>), add WQS-LB/LS:



3. Configure the WQS-LB/LS using AT commands or LoRaWAN downlinks

You can configure the WQS-LB/LS using AT Commands or LoRaWAN Downlinks.

- AT Commands: See [FAQ](#).
- LoRaWAN Downlink instruction for different platforms: [Use Note for Server](#) (IoT LoRaWAN Server)

There are two types of commands to configure the WQS-LB/LS:

1. General Commands - They are the same for all Dragino devices that support the DLWS-005 LoRaWAN Stack (**Note****). These commands can be found on the wiki: [End Device Downlink Command](#). These commands are used to configure:

- General system settings, such as the uplink interval.
- LoRaWAN protocol and radio-related settings.

Note: Please refer to the earlier user manual if you don't have firmware version 1.8.0.

2. Commands Specifically Designed for the WQS-LB/LS

These commands are valid only for the WQS-LB/LS, as shown below:

3.1 Set transmit interval time

Feature: Set the uplink interval.

AT command:

Command	AT+TDC
---------	--------

Parameters	time : uplink interval in milliseconds
Get	AT+TDC=?
Response	time in milliseconds OK
Set	AT+TDC=<time>
Response	OK
Example	AT+TDC=60000 Set uplink interval to 60 seconds

Downlink command:

Prefix	0x01
Parameters	time : uplink interval in seconds, 3 bytes in hexadecimal.
Payload	<prefix><time>
Example	0100003C Set uplink interval to 60 seconds

3.2 Set interrupt mode

Feature: Set the interrupt mode.

AT command:

Command	AT+INTMOD
Parameters	interrupt_mode : 0 : Disable interrupt 1 : Trigger by rising and falling edge 2 : Trigger by falling edge 3 : Trigger by rising edge
Get	AT+INTMOD=?
Response	interrupt mode OK

Set	AT+INTMOD=<interrupt_mode>
Response	OK
Example	AT+INTMOD=2 Set the interrupt mode to 'trigger by falling edge'

3.3 Set power output duration

Feature: Set power output duration

AT Command:

Command	AT+5VT
Parameters	time : power output duration in milliseconds
Get	AT+5VT=?
Response	time OK
Set	AT+5VT=<time>
Response	OK
Example	AT+5VT=1000 Close after a delay of 1000 milliseconds

Downlink Command:

Prefix	0x07
Parameters	time : power output duration in seconds, 2 bytes in hexadecimal
Payload	<prefix><time>
Example	070000 Set to 0 0701F4 Set to 500 seconds

3.4 Sensor Calibration Commands

Specific operation steps

1. Put the sensor into the corresponding calibration liquid.
2. Restart the device.
3. Send calibration instructions.
4. Receive the byte corresponding to return.
5. Received OK is a successful calibration.
6. For EC200 calibration, please refer to [4.2.6](#)

Command Example	Function	Response
AT+CALPH=xx	Parameter 4 6 9 downlink: 0xFB XX	4:10 06 00 22 ff ff 2b 31 6:10 06 00 21 ff ff db 31 9:10 06 00 20 ff ff 8a f1
AT+CALORP=xx	Parameter 86 256 downlink: 0xFC XX XX	86:13 06 00 24 ff ff cb 03 256:13 06 00 25 ff ff 9a c3
AT+CALEC=xx	Parameter 1 10 downlink: 0xFD XX	1:12 10 00 26 00 02 a2 a0 10:11 10 00 26 00 02 a2 93
AT+CALZD2=xx AT+CALZD4=xx	Parameters 0 1 downlink: 0xF1 00 downlink: 0xF1 01 Parameters 0 1 downlink: 0xF2 00 downlink: 0xF2 01	0:19 10 10 10 00 02 47 15 1:19 10 10 10 00 02 47 15 0:20 10 10 10 00 02 42 7c 1:20 10 10 10 00 02 42 7c

AT+CALNTU=xx	Parameters 0 2 4 6 8 10	0:15 06 00 5e 00 01 2a cc
	downlink: 0xFE 00	2:15 06 00 5e 00 02 6a cd
	downlink: 0xFE 02	4:15 06 00 5e 00 03 ab 0d
	downlink: 0xFE 04	6:15 06 00 5e 00 04 ea cf
	downlink: 0xFE 06	8:15 06 00 5e 00 05 2b 0f
	downlink: 0xFE 08	10:15 06 00 5e 00 06 6b 0e
	downlink: 0xFE 0a	

3.5 RS485 Test Command

AT Command:

Command Example	Function	Response
AT+RSWRITE=xxxxxx	Send command to 485 sensor. Range : no more than 10 bytes	OK

Eg: Send command **01 03 00 00 00 01 84 0A** to 485 sensor

AT+RSWRITE=0103000001840A

Downlink Command:

- 0xE20103000001840A Same as: AT+RSWRITE=0103000001840A

4. Water Quality Sensors

4.1 pH Sensor

The PH01 is a device used to measure the pH value (hydrogen ion concentration index), indicating the acidity or alkalinity of a solution. It features an integrated design, making it lighter, simpler in structure, and more convenient to use. The device has an IP68 waterproof rating. The reference electrode uses a double salt bridge design, providing enhanced resistance to pollution. This product is ideal for applications in industrial sewage, domestic sewage, agriculture, aquaculture, and other settings involving non-corrosive weak acid and weak alkali environments.

4.1.1 Features

- pH measurement range: 0–14 pH, with a resolution of 0.01 pH.
- One-piece design with a light, simple structure, making it easy to use.

- The reference electrode features a double salt bridge design, offering stronger anti-pollution resistance and an IP68 waterproof rating.
- The device uses a wide voltage power supply, ranging from DC 7V to 30V.

4.1.2 Specifications

- **Power supply:** DC 7–30V
- **Power consumption:** $\leq 0.5W$
- **Communication interface:** RS485, standard MODBUS-RTU protocol; communication baud rate: default 9600
- **pH measurement range:** 0–14.00 pH; resolution: 0.01 pH
- **pH measurement error:** ± 0.15 pH
- **Repeatability error:** ± 0.02 pH
- **Working environment:**
 - Ambient Temperature: 0–60°C
 - Relative Humidity: <85% RH(Specifically refers to the cable male and female)
- **Waterproof rating:** IP68
- **Pressure resistance:** 0.6 MPa
- **Wire length:** 5 meters
- **Lifespan:** 1 years under normal use

4.1.3 Dimensions

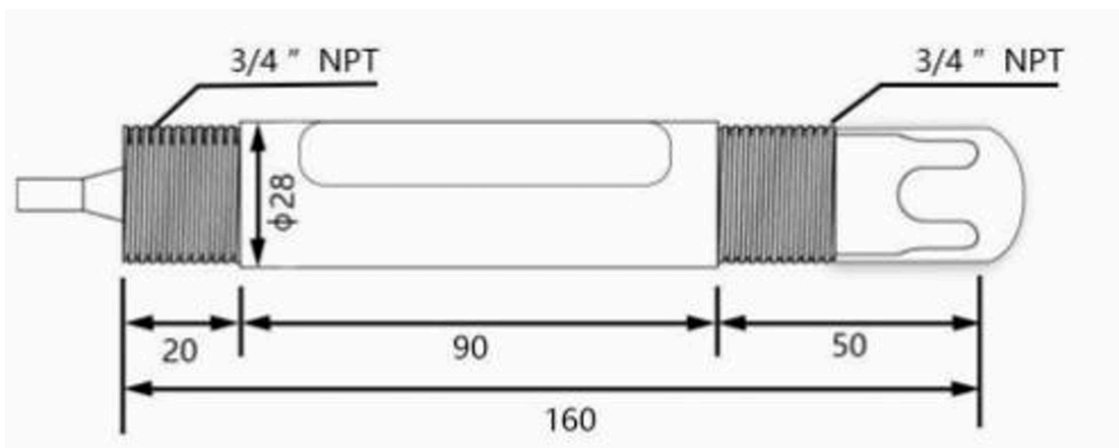

4.1.4 Installation

Do not power on while connecting the cables. Double-check the wiring before powering it on.

Installation diagrams are shown below for your reference (see submerged installation and pipeline installation):

Submerged installation:

The lead wire of the equipment passes through the waterproof pipe, and the 3/4-inch thread on the top of the device is connected to the 3/4-inch thread of the waterproof pipe using thread seal tape. Ensure that the top of the equipment and the device wire are not exposed to water.

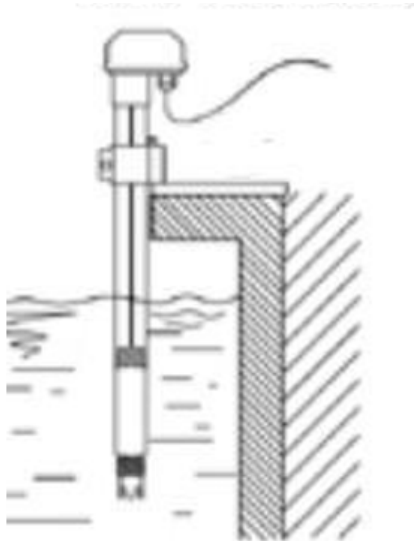

Pipeline installation:

Connect the device to the pipeline using the 3/4-inch thread.

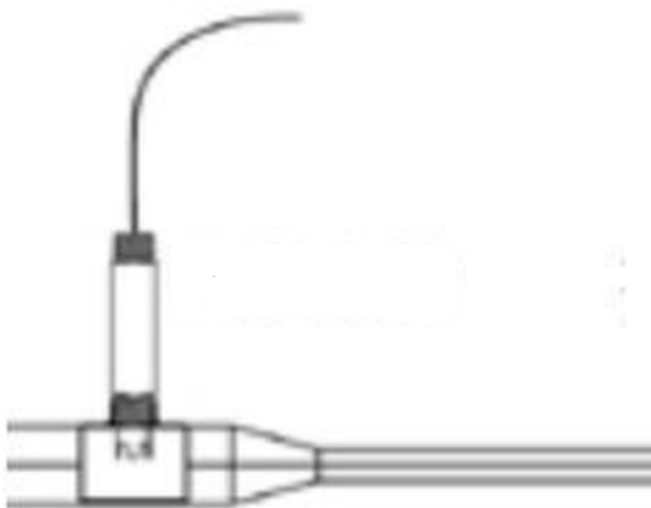

Sampling:

Take representative water samples according to the sampling requirements. If it is inconvenient to take samples, you can also place the electrode into the solution to be tested and read the output data. After some time, remove the electrode and clean it.

Measure the pH of the water sample:

First, rinse the electrode with distilled water, then with the water sample. Immerse the electrode in the sample, gently shake the test cup or stir to accelerate the electrode's stabilization. Allow it to stand and record the pH value once the reading stabilizes.

4.1.5 Maintenance

- **General Maintenance:**

The equipment generally does not require daily maintenance. However, if an obvious fault occurs, please do not attempt to open or repair it yourself. Contact us as soon as possible!

- **Soaking Solution:**

There is an appropriate amount of soaking solution in the protective bottle at the front end of the electrode. The electrode head is soaked in it to keep the glass bulb and liquid junction active.

When measuring, loosen the bottle cap, pull out the electrode, and rinse it with pure water before use.

- **Preparation of Electrode Soaking Solution:**

- Take a packet of pH 4.00 buffer, dissolve it in 250 ml of pure water, and soak it in 3M potassium chloride solution.
- To prepare the solution: dissolve 25 grams of analytical-grade potassium chloride in 100 ml of pure water.

- **Handling of the Electrode:**

The glass bulb at the front end of the electrode should not come into contact with hard objects. Any damage or scratches will make the electrode ineffective.

- **Before Measurement:**

Shake off any bubbles in the electrode's glass bulb, as they will affect the measurement.

While measuring, the electrode should be stirred in the sample solution, then allowed to rest to accelerate the response.

- **Cleaning:**

The electrode should be cleaned with deionized water before and after each measurement to ensure accuracy.

- **Passivation of the pH Electrode:**

After long-term use, the pH electrode may become passivated, which is characterized by a decrease in sensitivity, slow response, and inaccurate readings.

- In this case, soak the bulb at the bottom of the electrode in 0.1M dilute hydrochloric acid for 24 hours (0.1M dilute hydrochloric acid preparation: dilute 9 ml of hydrochloric acid to 1000 ml with distilled water), and then soak it in 3.3M potassium chloride solution for 24 hours.
- If the electrode is seriously passivated and soaking in 0.1M hydrochloric acid has no effect, the pH electrode bulb can be soaked in 4% HF (hydrofluoric acid) for 3-5 seconds, washed with pure water, and then soaked in 3.3M potassium chloride solution for 24 hours to restore its performance.

- **Contamination and Blockage:**

Contamination of the glass bulb or blockage of the liquid junction can also cause electrode passivation. In this case, clean the electrode with an appropriate solution based on the nature of the contaminant.

- **Calibration:**

The equipment should be calibrated before each use.

For long-term use, it is recommended to calibrate every 3 months. The calibration frequency should be adjusted based on different application conditions (e.g., degree of dirt, deposition of chemical substances).

- **Electrode Replacement:**

After prolonged use, replace the electrodes in a timely manner.

4.1.6 Calibration

This device uses a three-point calibration, requiring the preparation of three known pH standard solutions.

The steps are as follows:

1. Wash the electrode with distilled water and place it in the 9.18 standard buffer solution. Once the data stabilizes, enter the following calibration command to complete the 9.18 calibration:

AT+CALPH=9

Downlink: 0xFB 09

2. Wash the electrode with distilled water and place it in the 6.86 standard buffer solution. Once the data stabilizes, enter the following calibration command to complete the 6.86 calibration:

AT+CALPH=6

Downlink: 0xFB 06

3. Wash the electrode with distilled water and place it in the 4.01 standard buffer solution. Once the data stabilizes, enter the following calibration command to complete the 4.00 calibration:

AT+CALPH=4

Downlink: 0xFB 04

4.2 EC Sensor

EC K1/K10/200 is a device used for measuring the conductivity of solutions. It adopts an integrated design, making it lighter, simpler in structure, and more convenient to use.

EC K1/K10 has a waterproof rating of IP68 and can be widely used in continuous monitoring of the conductivity of aqueous solutions such as cross-section water quality, aquaculture, sewage treatment, environmental protection, pharmaceuticals, food, and tap water.

ECK1/K10 cannot be used in seawater. EC200 can be used in high conductivity environments such as seawater.

4.2.1 Features

- Conductivity measurement range: 0-2000 $\mu\text{S}/\text{cm}$; 10-20000 $\mu\text{S}/\text{cm}$; 1-200000 $\mu\text{S}/\text{cm}$.
- Integrated design with a light and simple structure, easy to use.
- Waterproof grade: IP68.
- RS485 communication interface: Modbus RTU protocol, easily connected to a computer for monitoring and communication.
- Modbus communication address can be set, and baud rate can be modified.
- Wide voltage power supply: DC 7-30V is supported.

4.2.2 Specifications

- **Power supply:** DC 7-30V
- **Power consumption:** $\leq 0.5\text{W}$
- **Communication interface:** RS485; standard MODBUS-RTU protocol; communication baud rate: default 9600
- **Conductivity measurement range:**
 - K=1: 0-2000 $\mu\text{S}/\text{cm}$; resolution: 1 $\mu\text{S}/\text{cm}$
 - K=10: 10-20000 $\mu\text{S}/\text{cm}$; resolution: 10 $\mu\text{S}/\text{cm}$
 - 200: 1-200000 $\mu\text{S}/\text{cm}$; resolution: 1 $\mu\text{S}/\text{cm}$
- **Conductivity measurement error:** $\pm 1\%$ FS
- **Working environment:**

- Ambient Temperature: 0–60°C
- Relative Humidity: <85% RH (Specifically refers to the cable male and female)
- **Waterproof grade:** IP68
- **Pressure resistance:** 0.6 MPa
- **Wire length:** 5 meters
- **EC200 Salinity measurement range:** 0-70 PSU, resolution: 0.1 PSU
- **Temperature measurement range:** ECK1/ECK10: -20 ~ +60°C, resolution: 0.1°C EC200: -5 ~ +80°C, resolution: 0.1°C
- **Temperature measurement error:** ±0.5°C
- **Temperature compensation range:** ECK1/ECK10: 0 ~ 60°C (default compensation temperature: 25°C)
ECK1/ECK10: -5 ~ +80°C (default compensation temperature: 25°C)
- **Default temperature compensation coefficient:** 0.02
- **Lifespan:** 1 years under normal use

4.2.3 Dimensions

EC K1/K10

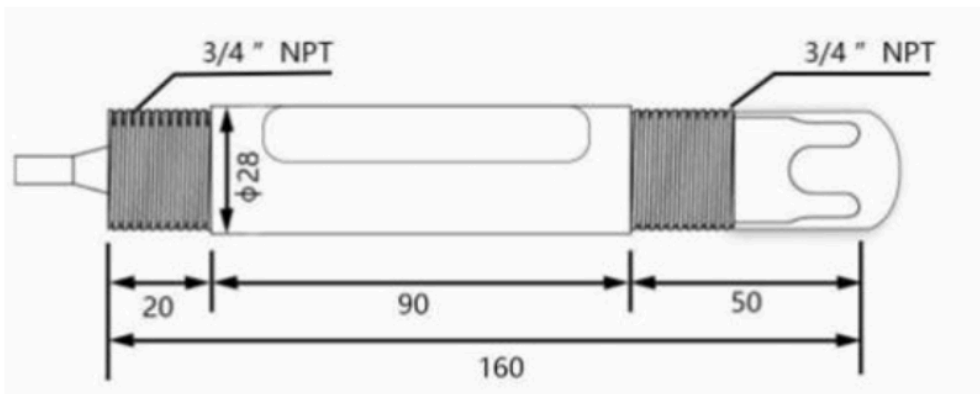

EC200

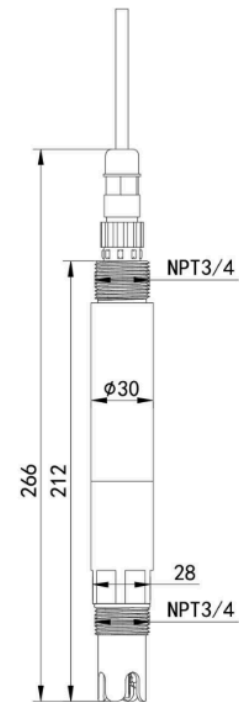

4.2.4 Installation

Selection of matching electrode constant:

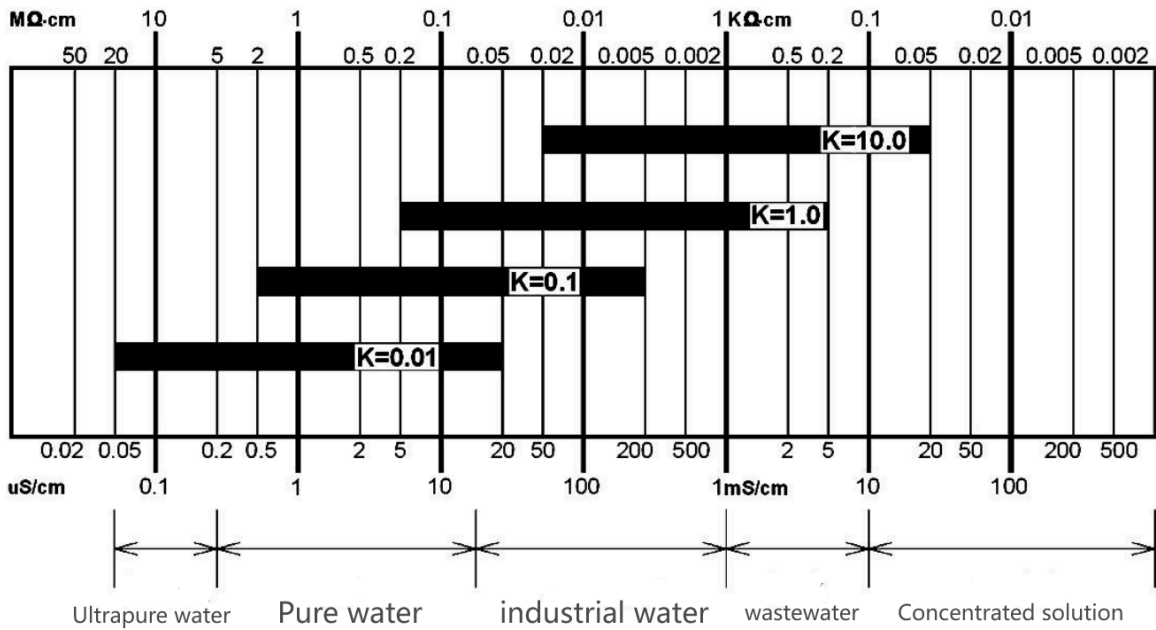

Electrode Installation Types

- A: Side wall installation
- B: Top flange installation
- C: Pipeline bend installation
- D: Another pipeline bend installation
- E: Flow-through installation
- F: Submerged installation

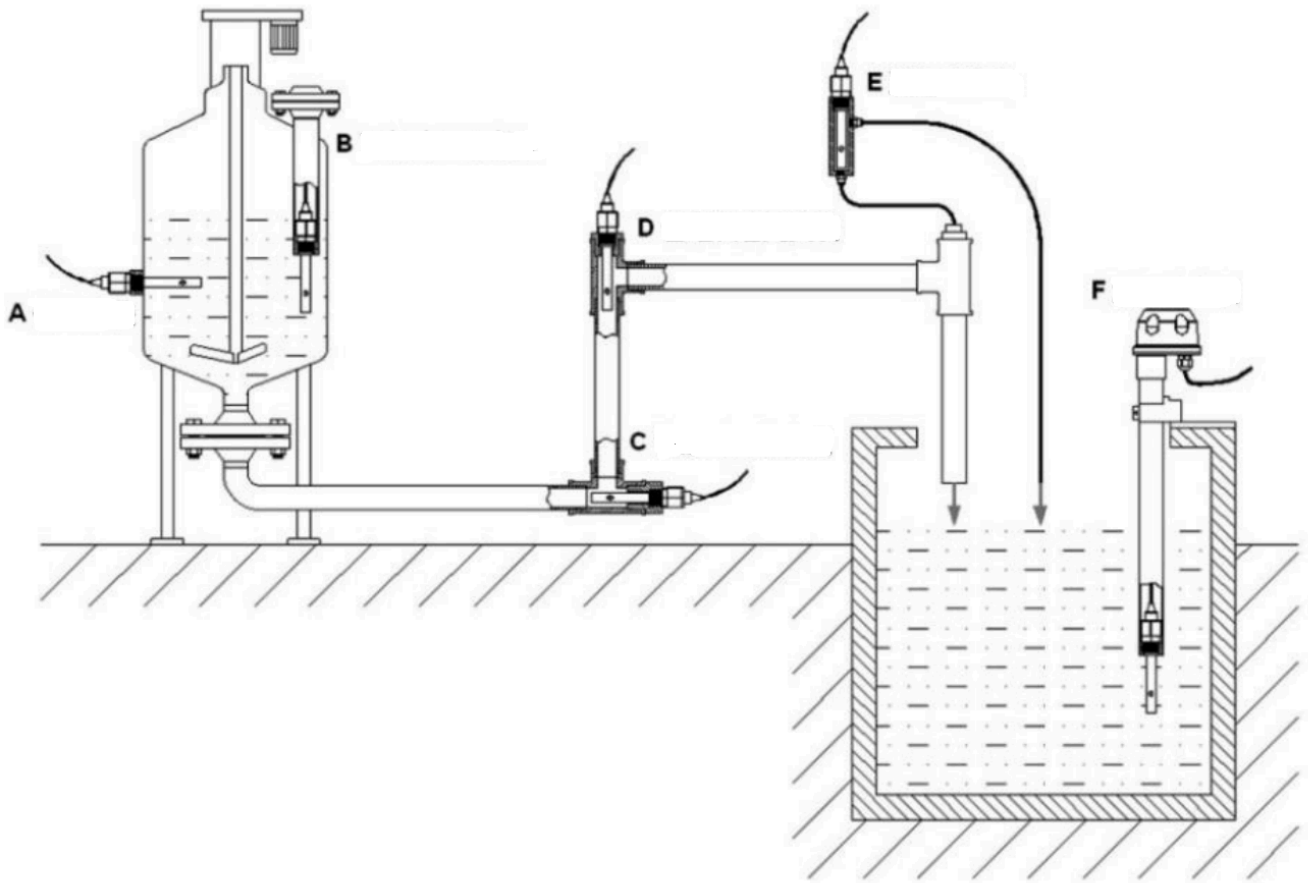

Several Common Installation Methods for Electrodes

When installing the sensor on-site, you should strictly follow the correct installation method shown in the following picture. Incorrect installation methods can cause data deviation.

A. Several common incorrect installation methods:

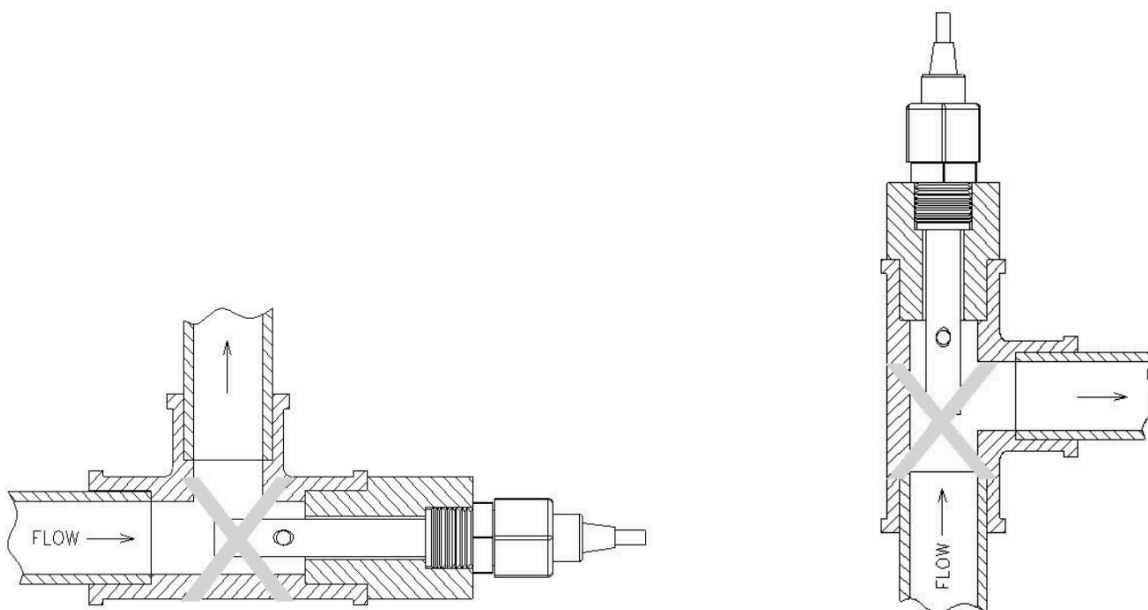

Error cause: The electrode joint is too long, and the extension part is too short. This causes the sensor to form a dead cavity, resulting in measurement errors.

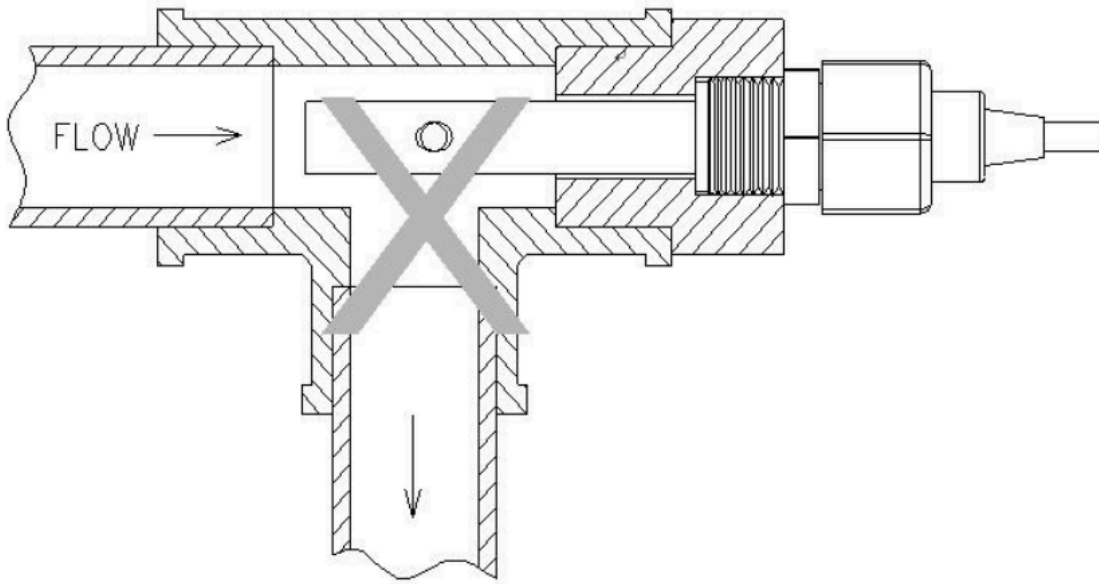

Error cause: Measurement errors or instability may occur if the water flow cannot fill the pipe or if air accumulates at high altitudes.

B. Correct installation method

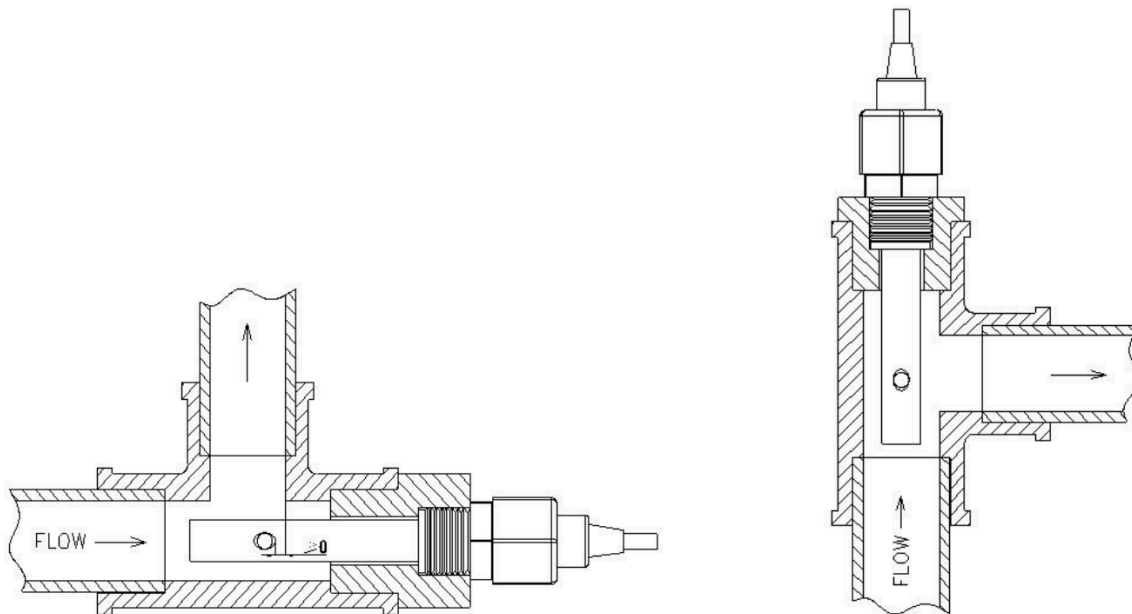

4.2.5 Maintenance

- The equipment itself generally does not require daily maintenance. When an obvious fault occurs, please do not attempt to open or repair it yourself; instead, contact us as soon as possible.
- If the electrode is not used for an extended period, it can generally be stored in a dry place. However, it must be placed (or stored) in distilled water for several hours before use to activate the electrode. Electrodes that are frequently used can be stored in distilled water.
- **Cleaning of conductivity electrodes:** Organic stains on the electrode can be cleaned with warm water containing detergent or alcohol. Calcium and magnesium precipitates are best cleaned with 10% citric

acid. The electrode plate or pole should only be cleaned using chemical methods or by shaking in water. Wiping the electrode plate will damage the coating (platinum black) on the electrode surface.

- The equipment should be calibrated before each use. For long-term use, it is recommended to calibrate it every 3 months. The calibration frequency should be adjusted appropriately based on different application conditions (e.g., degree of dirt in the application, deposition of chemical substances, etc.).

4.2.6 Calibration

This device uses one-point calibration, and you need to prepare a known E standard solution. When the range is $K=1$ (1–2000), use a 1413 $\mu\text{S}/\text{cm}$ standard solution. When the range is $K=10$ (10–20000), use a 12.88 mS/cm standard solution. When calibrating the EC200, you can use either 1413 $\mu\text{S}/\text{cm}$ or 111310 $\mu\text{S}/\text{cm}$.

The steps are as follows:

1. Put the electrode in distilled water to clean it. When the range is 1–2000, use the 1413 $\mu\text{S}/\text{cm}$ standard solution. After the data is stable, enter the following calibration command:

AT+CALEC=1

Downlink: **0xFD 01**

2. Put the electrode in distilled water to clean it. When the range is 10–20000, use the 12.88 mS/cm standard solution. After the data is stable, enter the following calibration command:

AT+CALEC=10

Downlink: **0xFD 10**

3. Put the electrode in distilled water to clean it. When the range is 0–200000, use the 1413 $\mu\text{S}/\text{cm}$ standard solution. After the data is stable, enter the following calibration command:

AT+RSWRITE=1610012000030600010000058529F2

Downlink: **0xE21610012000030600010000058529F2**

Then, place it in a 111310 $\mu\text{S}/\text{cm}$ solution for the second calibration. After the data is stable, enter the following calibration command:

AT+RSWRITE=1610012000030600020001b2ce0bF5

Downlink: **0xE21610012000030600020001b2ce0bF5**

4. If you're not satisfied with the calibrated data and need further adjustments, you can send the following command.

Example: If the conductivity output is 9900 and you want to correct it to 10000, the difference is $10000 - 9900 = 100$. $0100 \Rightarrow 64\text{H}$.

(Hexadecimal) Register contents: **00000064** (Specifically, you want to calibrate the data and then add the check digit and send it.)

AT+RSWRITE=16100051000204000000647800

Downlink: **0xE216100051000204000000647800**

4.3 ORP Sensor

The ORP01 is a device for measuring the redox potential of a solution. It features a high-purity platinum ORP composite electrode with strong resistance to acids and alkalis, excellent antioxidant capacity, high measurement accuracy, fast response, and good stability.

The electrode automatically compensates for temperature, making it suitable for online monitoring of the redox potential in cyanide-containing and chromium-containing wastewater.

4.3.1 Features

- **ORP Measurement Range:** -1999~1999 mV, resolution: 1 mV.
- **Applicable Electrode Temperature:** 0~80°C.
- **Electrode Material:** Made of high-purity platinum, offering strong resistance to acids and alkalis, excellent antioxidant capacity, high measurement accuracy, fast response, and good stability.
- **RS485 Communication Interface:** The ModBus-RTU communication protocol enables easy connection to a computer for monitoring and communication.
- **ModBus Features:** The communication address is configurable, and the baud rate can be modified.
- **Power Supply:** Operates with a wide voltage range, DC 7~30 V.

4.3.2 Specifications

- **Measuring Range:** -1999~1999 mV
- **Resolution:** 1 mV
- **Output Signal:** RS485
- **Measurement Error:** ± 3 mV
- **Stability:** ≤ 2 mV/24 hours
- **Working environment:**
 - Ambient Temperature: 0~60°C
 - Relative Humidity: <85% RH(Specifically refers to the cable male and female)
- **Waterproof Grade:** IP68
- **Pressure Resistance:** 0.6 MPa
- **Wire length:** 5 meters
- **Lifespan:** 1 years under normal use

4.3.3 Dimensions

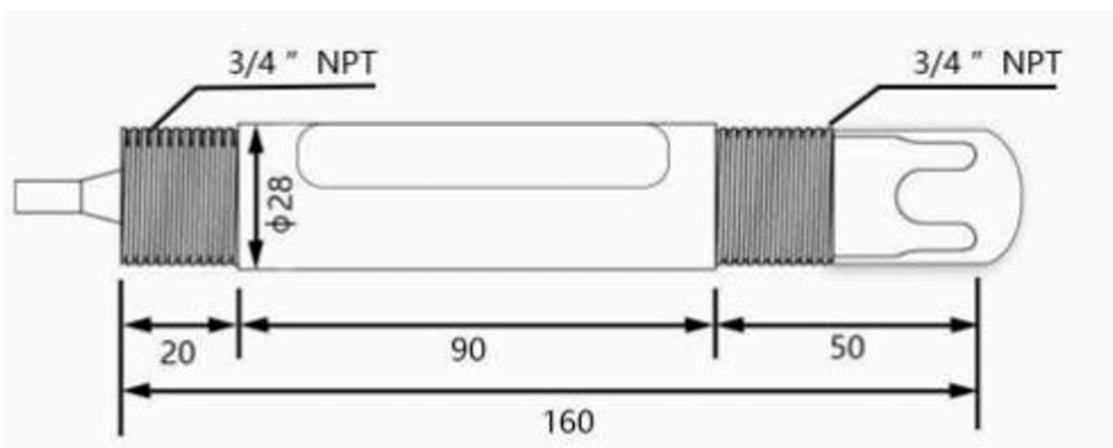

4.3.4 Installation Note

Do not power on while connecting the cables. Double-check the wiring before powering it on.

Installation diagrams are shown below for your reference (see submerged installation and pipeline installation):

Submerged installation:

The equipment's lead wire passes through a waterproof pipe, and the 3/4-inch thread on the top of the equipment is connected to the 3/4-inch thread of the waterproof pipe using raw tape. Ensure that both the top of the equipment and the equipment wire remain dry and are not submerged.

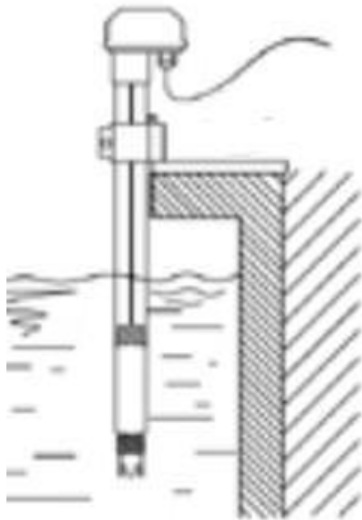

Pipeline installation:

Connect the equipment to the pipeline using the 3/4-inch thread.

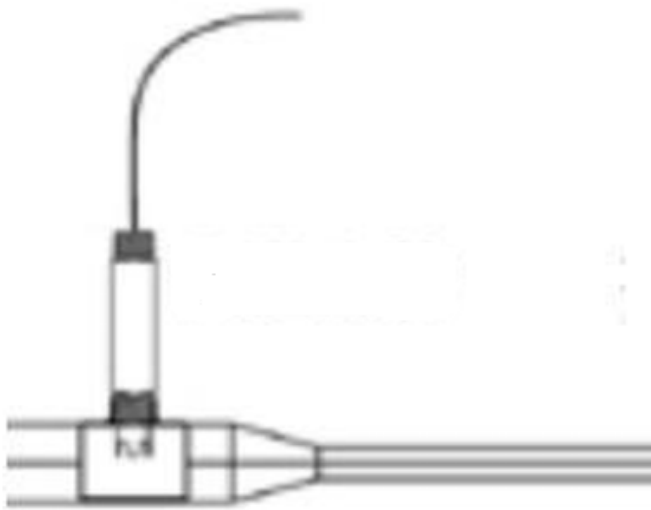

4.3.5 Maintenance

- The equipment itself generally does not require daily maintenance. If a significant fault occurs, do not attempt to open or repair it yourself. Please contact us as soon as possible.
- ORP electrodes typically do not require calibration and can be used directly. However, if there are concerns about the electrode's quality or test results, the electrode potential can be checked using an ORP standard solution. This will help determine whether the electrode meets measurement requirements. If necessary, recalibrate or replace the electrode. The frequency of electrode calibration or inspection depends on the application conditions, such as the level of dirt or the deposition of chemical substances.
- The protective bottle at the front end of the electrode contains an appropriate soaking solution to ensure the activation of the platinum sheet and the liquid junction. Before measuring, loosen the bottle cap, remove the electrode, and rinse it with pure water.

- **Preparation of Electrode Soaking Solution:** Dissolve 25 grams of analytical-grade potassium chloride in 100 ml of pure water to prepare a 3.3M potassium chloride solution.
- Before measuring, ensure there are no air bubbles in the electrode's glass bulb, as they can affect measurements. Shake off any bubbles, stir the electrode in the solution being measured, and then let it sit to accelerate the response.
- Clean the electrode with deionized water before and after each measurement to maintain accuracy.
- After long-term use, the ORP electrode may become passivated, resulting in reduced sensitivity, slower response, or inaccurate readings. To restore performance, soak the platinum sheet at the bottom of the electrode in 0.1M dilute hydrochloric acid for 24 hours (prepare by diluting 9 ml of hydrochloric acid with distilled water to 1000 ml). Then, soak the electrode in 3.3M potassium chloride solution for another 24 hours.
- Contamination or blockage of the liquid junction can also cause passivation. Clean the electrode using an appropriate solution based on the type of contaminant. If the platinum surface is severely contaminated with an oxide film, apply toothpaste to the surface and gently scrub to restore its luster.
- Calibrate the equipment before each use. For long-term use, calibration is recommended every three months, with the frequency adjusted based on application conditions (e.g., dirt levels or chemical deposition). Replace aging electrodes promptly.

4.3.6 Calibration

The OPR01 uses two-point calibration. To perform the calibration, you need two known ORP standard solutions.

Clean the electrode with distilled water. Place it in an 86 mV standard buffer, wait for the data to stabilize, and then enter the following calibration command to complete the 86 mV point calibration:

AT+CALORP=86

downlink: 0xFC 00 56

Clean the electrode with distilled water again. Place it in a 256 mV standard buffer, wait for the data to stabilize, and then enter the following calibration command to complete the 256 mV point calibration:

AT+CALORP=256

downlink: 0xFC 01 00

4.4 Dissolved Oxygen Sensor

The fluorescence dissolved oxygen sensor is a newly developed online digital sensor, utilizing imported components, advanced production technology, and surface-mounting technology.

It features an IP68 waterproof rating, and its cable is seawater-proof. The sensor can be directly submerged in water without a protective tube, ensuring long-term stability, reliability, and accuracy.

The fluorescence dissolved oxygen sensor operates based on the principle of quenching active fluorescence by specific substances in physics.

A blue light emitted by a light-emitting diode (LED) shines on the fluorescent material located on the inner surface of the fluorescent cap.

This fluorescent material is excited and emits red light.

By detecting the phase difference between the red light and the blue light and comparing it with the internal calibration value, the concentration of oxygen molecules is calculated. The final value is automatically compensated for temperature and air pressure.

4.4.1 Features

- Compact size, low power consumption, and easy portability.
- Achieves low cost, low price, and high performance.
- High integration, long lifespan, and high reliability.
- Supports up to four isolations, resistant to complex interference conditions on-site, with a waterproof rating of IP68.
- The electrode uses a high-quality, low-noise cable, enabling the signal output length to exceed 20 meters.

4.4.2 Specifications

- **Measuring range:** 0–20 mg/L, 0–50°C
- **Accuracy:** ±3%, ±0.5°C
- **Resolution:** 0.01 mg/L, 0.01°C
- **Maximum operating pressure:** 6 bar
- **Output signal:**
 - **A:** 4–20 mA (current loop)
 - **B:** RS485 (standard Modbus-RTU protocol, default device address: 01)
- **Power supply voltage:** 5–24 V DC
- **Working environment:**
 - Ambient Temperature: 0–60°C
 - Relative Humidity: <85% RH(Specifically refers to the cable male and female)
- **Power consumption:** ≤0.5 W
- **Wire length:** 5 meters
- **Lifespan:** 1 years under normal use

4.4.3 Dimensions

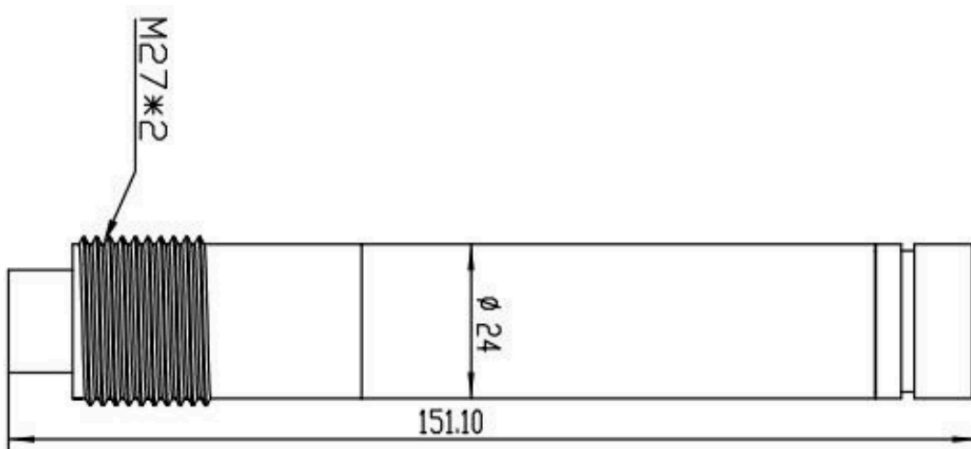

4.4.4 Instructions for use and maintenance

- **Sampling:** Take representative water samples following the sampling requirements.
- **Determine dissolved oxygen in water samples:**
 - Rinse the electrode three times with distilled water, then rinse it three times with the water sample.
 - Immerse the electrode in the sample, carefully shake the test cup or stir the solution to accelerate electrode stabilization.
 - Let the sample stand and record the dissolved oxygen when the reading becomes stable.
- **Alternative measurement method:**
 - If taking samples is inconvenient, place the electrode directly in the measured solution.
 - Wait for the reading to stabilize, record the output data, and remove the electrode after a period of time.
 - Clean the electrode afterward.
- **Post-measurement care:**
 - After measuring the sample, rinse the electrode three times with distilled water.
 - Store the electrode upright in the protective solution.

Note: When measuring multiple samples, clean the electrode before proceeding to the next sample to avoid contamination and ensure accurate results.

Additional Tip: If the water conditions are complex and precise data is required, clean the sensor probe frequently.

4.4.5 Precautions

- To ensure accurate measurements on the pipeline, avoid bubbles in the measuring cells, as they can cause data inaccuracies.
- Verify that the packaging is intact and that the product model matches the selected model.
- Do not connect the wires while the power is on. Turn on the power only after completing and verifying the wiring.
- Avoid altering components or wires that were soldered at the factory when using the product.
- The sensor is a precision device. Do not disassemble it, or allow the sensor surface to come into contact with sharp objects or corrosive liquids, to prevent damage.

4.5 Turbidity Sensor

This basic digital turbidity transmitter for routine water quality monitoring utilizes the proven 90° scattered light principle, an infrared LED light source, and a fiber-optic optical path. An internal filtering algorithm provides strong resistance to external light interference. A built-in temperature transmitter provides automatic temperature compensation, making it suitable for long-term online monitoring.

4.5.1 Features

- Turbidity measurement range: TS200: 0~200 NTU; TS4000: 0~ 4000NTU; TS01
- Waterproof rating: IP68.

- Light filtering algorithm, strong resistance to external light interference, and automatic temperature compensation make it suitable for long-term online monitoring environments.
- RS485 communication interface: MODBUS RTU communication protocol allows for convenient connection to a computer for monitoring and communication.
- The ModBus communication address and baud rate are configurable.
- The device accepts a wide voltage supply, supporting DC 10-30V operation.

4.5.2 Specifications

- **Measuring range:** TS200: 0~200 NTU; TS4000: 0~ 4000NTU; TS01:0~1000NTU
- **Accuracy:** $\pm 5\%FS$ (25°C) ; $\pm 0.5^\circ C$ (TS1 has no temperature related parameters)
- **Resolution:** Turbidity 0.1 NTU/1NTU;temperature 0.1°C
- **Operating temperature:** 0-40°C
- **Power supply:** DC 10-30V
- **Power consumption:** 0.2W
- **Communication interface:** RS485; standard MODBUS-RTU protocol; Baud rate: Default: 9600 (configurable to 1200, 2400, 4800, 9600, 19200, 38400, 57600, and 115200)
- **Measurement principle:** 90° light scattering
- **Lifespan:** 1 years under normal use
- **Waterproof rating:** IP68
- **Electrode cable length:** 5m by default
- **Casing material:** corrosion-resistant plastic

4.5.3 Dimensions

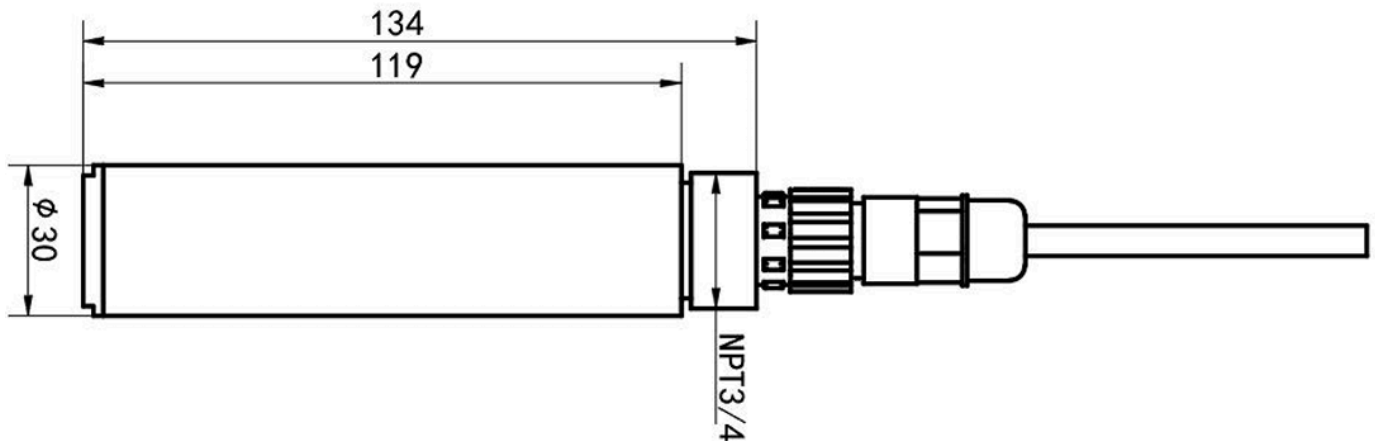

4.5.4 Instructions for use and maintenance

- The sensor can be directly submerged in water without requiring a protective tube, ensuring long-term stability, reliability, and accuracy.
- If water conditions are complex and accurate data is needed, the sensor probe should be wiped frequently.

4.5.5 Calibration

For turbidity calibration, you only need to prepare a solution. You can choose from 0 NTU, 200 NTU, 4000 NTU, and then enter the corresponding calibration command.

"AT+CALZD2=0" downlink:0xF1 00	0NTU turbidity solution
"AT+CALZD2=1" downlink:0xF1 01	200NTU turbidity solution
"AT+CALZD4=0" downlink:0xF2 00	0NTU turbidity solution
"AT+CALZD4=1" downlink:0xF2 01	4000NTU turbidity solution

The following applies to the calibration of the **TS01** sensor:

"AT+CALNTU=0" downlink:0xFE 00	0NTU turbidity solution
"AT+CALNTU=2" downlink:0xFE 02	200NTU turbidity solution
"AT+CALNTU=4" downlink:0xFE 04	400NTU turbidity solution
"AT+CALNTU=6" downlink:0xFE 06	600NTU turbidity solution
"AT+CALNTU=8" downlink:0xFE 08	800NTU turbidity solution
"AT+CALNTU=10" downlink:0xFE 0A	1000NTU turbidity solution

4.5.6 Precautions

- To ensure the electrode measures correctly on the pipeline, avoid bubbles between the measuring cells, as they may cause data inaccuracies.
- Check whether the packaging is intact and whether the product model matches the selected model.
- Do not connect the wires while the power is on. Turn on the power only after the wiring has been completed and verified.
- Do not alter the components or wires that have been factory-welded when using the product.
- The sensor is a precision device. Do not disassemble it or allow the sensor surface to come into contact with sharp objects or corrosive liquids, as this may damage the product.
- Do not power on while connecting the cables. Double-check the wiring before turning on the power.

5. DR-CL Water CL Probe

DR-CL is a device for measuring the residual chlorine concentration (hypochlorous acid, hypochlorite ion concentration) in water.

5.1 Specification:

- **Power Input:** DC7~30
- **Power Consumption :** 0.19W
- **Interface:** RS485. 9600 Baud Rate
- **CL Range & Resolution:**

- **CL2ML:**0-2mg/L
- **CL10ML:**0-10mg/L
- **Resolution:**0.01mg/L
- **CL Accuracy:** ±5% FS
- **Temperature Accuracy:** ±0.5 °C
- **Working environment:**
 - Ambient Temperature: 0–50°C
 - pH:4-9
 - Flow rate: 30L/h~60L/h (flow tank installation)
- **IP Rated:** IP68
- **Max Pressure:** 0.6MPa
- **Wire length:** 5 meters
- **Lifespan:**1 years under normal use

5.2 Mechanical Drawing

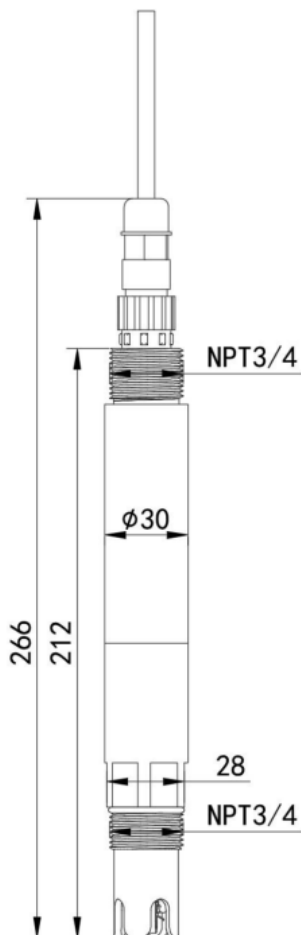

5.3 Maintenance

- The device itself generally does not require daily maintenance. When an obvious fault occurs, please do not open it and repair it yourself, and contact us as soon as possible!
- After using the electrode, please clean the electrode head with clean water and cover it with a protective cover.

- When measuring the device, the measured liquid should flow and the flow rate should be uniform, and there should be no bubbles attached to the measuring end of the device.
- If the electrode diaphragm is attached with dirt and mineral components, the sensitivity will be reduced, and it may not be possible to perform sufficient measurement. Please ensure that the platinum ring is clean.
- The platinum induction ring of a good residual chlorine electrode should always be kept clean and bright. If the platinum ring of the electrode becomes rough or covered with pollutants after measurement, please clean it according to the following method: (For reference) Inorganic pollution: immerse the electrode in 0.1mol/L dilute hydrochloric acid for 15 minutes, gently wipe the platinum ring of the residual chlorine electrode with a cotton swab, and then wash it with tap water.
- Organic or oil pollution: immerse the electrode in tap water with a small amount of detergent, such as dishwashing liquid, and thoroughly clean the sensing surface of the electrode sensor. Gently wipe the platinum ring of the electrode with a cotton swab, then rinse with tap water, and the cleaning is complete. If the platinum ring of the electrode has formed an oxide film, please use toothpaste or 1000-grit fine sandpaper to properly polish the sensing surface, and then clean it with tap water. The platinum ring is connected to the glass, so please handle it carefully when polishing.
The electrode has a service life of about one year, and a new electrode should be replaced in time after aging.
- Before the cable plug and the device plug are locked, do not put the plug part into water.

6. More detailed information about water quality sensors

[Water Quality Sensors](#) 

7. OTA Firmware update

User can change firmware WQS-LB/LS to:

- Change Frequency band/ region.
- Update with new features.
- Fix bugs.

Firmware and changelog can be downloaded from : [Firmware download link](#) 

Methods to Update Firmware:

- (Recommended way) OTA firmware update via wireless: <http://wiki.dragino.com/xwiki/bin/view/Main/Firmware%20OTA%20Update%20for%20Senso>
- Update through UART TTL interface: [Instruction](#) .

8. FAQ

8.1 External Power Supply Connection (For Battery Depletion/Multi-Sensor Use)

The WQS-LB/LS system includes a 1-to-3 splitter cable for connecting multiple water quality sensors simultaneously. Please be aware that power consumption increases with each additional sensor connected. External power is strongly recommended when:

- The battery is depleted
- Operating 2-3 sensors simultaneously
- For extended monitoring periods

Connection Method:

- Disconnect the battery wires
- Use a power supply with 3.3V voltage and 2A current rating, connecting it to the battery terminals

Recommended Power Specifications: 3.3V/2A external supply

Compatible Power Adapter:



Connector Type:



8.2 Why is there no LED response when I press the button on the solar panel model?

If the LED does not light up when you press the button, it may be because the battery has entered protection mode.

Solution: To reactivate the battery, simply expose the solar panel to direct sunlight.

For more details, please refer to: [Battery Protection State \(Apply to Solar Panel + Li-ion battery\)](#)

9. Order Info

9.1 Main Unit

Part Number: **WQS-LB/LS-XX**

XX: The default frequency band

- **AS923:** LoRaWAN AS923 band
- **AU915:** LoRaWAN AU915 band
- **EU433:** LoRaWAN EU433 band
- **EU868:** LoRaWAN EU868 band
- **KR920:** LoRaWAN KR920 band
- **US915:** LoRaWAN US915 band
- **IN865:** LoRaWAN IN865 band
- **CN470:** LoRaWAN CN470 band

9.2 Sensors

Sensor Model	Part Number
PH Sensor	DR-PH01
EC K1 Sensor	DR-ECK1.0
EC K10 Sensor	DR-ECK10.0
EC 200 Sensor	DR-EC200
ORP Sensor	DR-ORP1
Dissolved Oxygen Sensor	DR-DO1
Turbidity Sensor	DR-TS1
Turbidity 200 Sensor	DR-TS200

Turbidity 4000 Sensor	DR-TS4000
CL 2ML sensor	DR-CL-2ML
CL 10ML sensor	DR-CL-10ML

10. Support

- Support is available **Monday to Friday, from 09:00 to 18:00 GMT+8**. Due to different time zones, we are unable to offer live support. However, your questions will be answered as soon as possible during the aforementioned hours.

Please provide as much information as possible regarding your inquiry (e.g., product models, a detailed description of the issue, and steps to replicate it), and send an email to support@dragino.com.