

Pearl Curtain Beam Detector

GJD140 / GJD141



IP65, Suitable for outdoor use



Masking protection to prevent intruder tampering



Dualtech sensor for reliable alarm detection



Temperature compensation for extreme environments



Detection range selectable
3m - 12m

PACKAGE CONTENTS

- 1 x Pearl body
- 1 x T-bracket assembly
- 4 x wall plugs
- 4 x wall fixing screws
- 1 x drilling template
- 1 x opening tool

INTRODUCTION

The Pearl Detector is an outdoor motion detector with dual detection technology and anti-masking that uses PIR and microwave detection.

Both sensors must trigger to cause the detector to alarm ensuring precise and reliable presence detection. The detector has three N/C outputs for alarm, masking and tamper triggering.

QUICK INSTALLATION

1. Mount the detector following the instructions in sections "Mounting the Unit" and "Detector Placement and Beam Pattern".
2. Power the unit and ensure switch 1 is set to ON. The unit will flash for two minutes during this time. Fit the front cover on the unit and when the unit has finished flashing it will be ready for walk testing.

MOUNTING THE UNIT

During installation, protect the electronics against water as trapped moisture can affect or damage the unit.

BASIC INSTALLATION, BEAM OUTWARD FROM SURFACE (see figures 2,3,11,13)

1. Use drilling template to locate the two mounting holes (A figure 2).
2. Next feed the cable through rear or side knock-outs and then fix to the wall (B & C figure 2).

INSTALLATION WITH T-BRACKET ASSEMBLY, BEAM ACROSS SURFACE (see figures 4,5,12,14)

1. Use drilling template to locate the four mounting holes (A figure 4).
2. Next feed the cable through rear or side knock-outs (B figure 4) and out through cable access point. Fix to the wall and then secure the blanking plate onto the unused side of the T-bracket (figure 5,15).

FRONT ASSEMBLY (see figure 6-10)

1. Feed cable through grommet. Clip middle section shown into lower part of back section (figure 8) push back until flat to wall. Cut and wire the cable into the terminal blocks (figure 6,7)
2. Push the bottom of the front cover into clip on the middle section and rotate back flat to the wall (figure 8). Secure by tightening the screw in access hole. Finally push fit screw cover.
3. To access the unit once installed first lever off the screw cover (see figure 9). Unscrew the screw in the access hole. Next reverse steps shown in (figure 8) or to remove from the wall use provided clip to lever off the wall mounting (see figure 10).

DETECTOR PLACEMENT AND BEAM PATTERN (see figure 12 -15)

The detector uses microwave and infrared sensing to determine motion detection. The optimum position of the detector should be chosen to detect an intruder crossing the beam pattern (figure 13), and to avoid traffic from roads and paths (figure 14).

For applications where the T-bracket is used ensure the angle of the detector is pointing 2° away from the building (figure 15).

The detector should be at an optimum height of 2-2.5m. Secure the detector to a wall or solid fixture.

Two detectors must not be fitted back to back on the T-bracket. A minimum space of 2 metres must be left between detectors.

PROGRAMMING

The detector can be programmed with different range and sensitivity options and also LED indication. This can be done by changing the four DIP switch settings on the detector PCB (see figure 6). The range can be set to 3, 6, 9 or 12m and the sensitivity can be changed to high or low.

WALK TEST

Set the LED Indication to Enabled (figure 6). On power up the LED will flash red and green alternately for 2 minutes. The detector will then indicate an alarm condition with a red LED.

The alarm detection will flash red for 1s with an interval of 5s between detections when LED indication is ON.

The masking condition is indicated with a continuous green led indication when LED indication is ON.

MASKING OUTPUT

A masking event will be triggered after 60s of masking of the lens. The masking output will be cleared by removing the masking object. To re-calibrate the masking reset power to the device or change a DIP setting and replace the cover and allow to calibrate.

SPECIFICATIONS

Part Number	GJD140 - GJD141 Silver GJD140/W -GJD141/W White
Detection selectable range	3m 6m 9m 12m
Normally Closed Alarm	50mA 24Vdc Alarm time 10s
Normally Closed Masking	50mA 24Vdc
Normally Closed Tamper	with 20Ω impedance 50mA
Power input	12V +/- 3V @ max 40mA
*During installation the DC supply fault current shall be limited to a maximum of 1A	
Operating temperature	-20°C to +55°C
Temperature compensation	Digital
Microwave Frequencies	GJD 140 10.587GHz, GJD 141 10.525GHz
Maximum Beam Pattern Area	12 x 2m
Dimensions	117mm[h] x 44mm[w] x 41mm[d]
T-Bracket	120mm[h] x 68mm[w] x 50mm[d]
Boxed	125mm[h] x 93mm[w] x 58mm[d]
Weight	139g
Packed weight	201g
Cable (<200m)	8 core 7/0.2mm
Walk Test	Using LED Indication
Recommended Mounting Height	2 - 2.5 m
Swivel Bracket Accessory	GJD149 - Silver GJD149/W - White

1

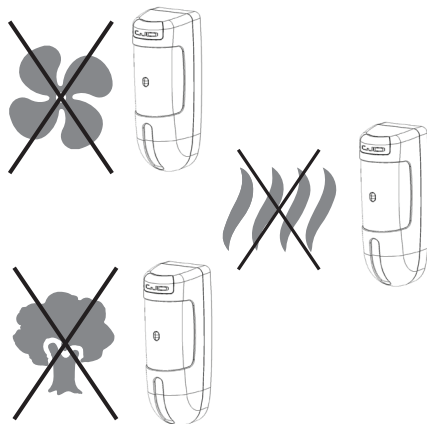

2

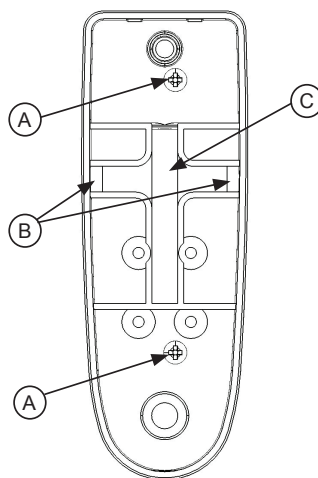

3

4

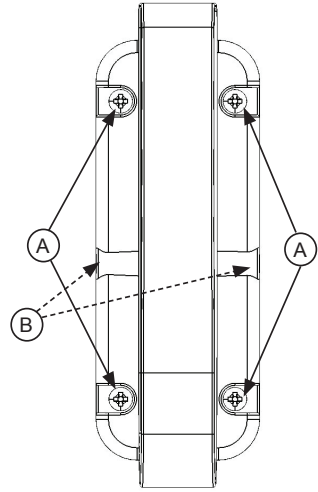
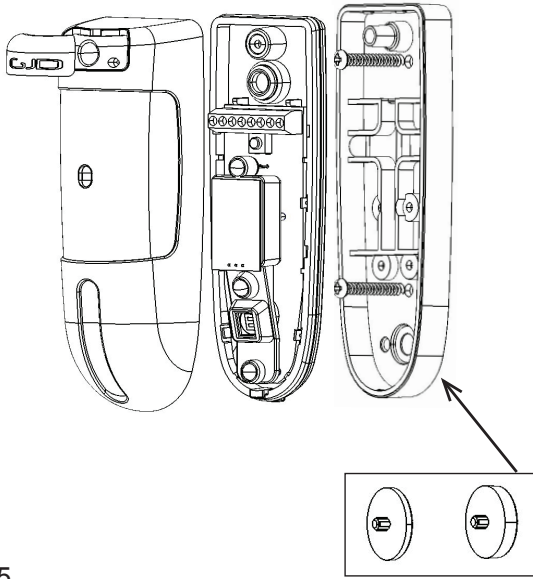

5

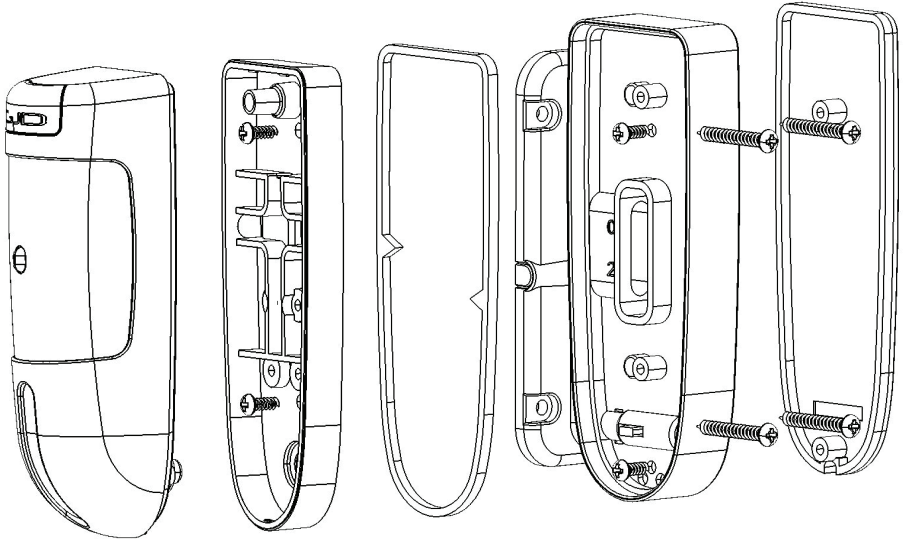

6

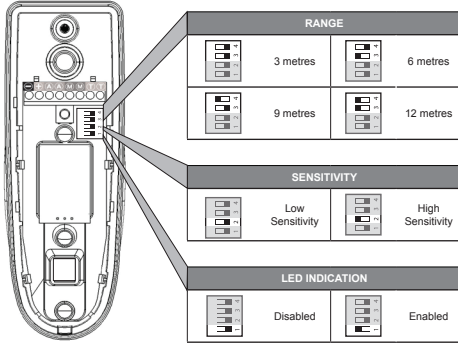

8

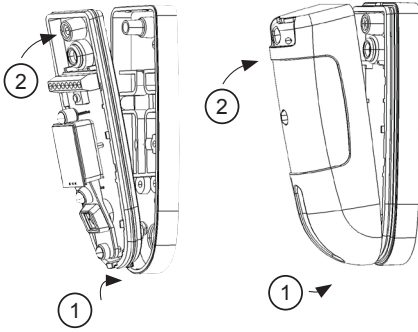

10

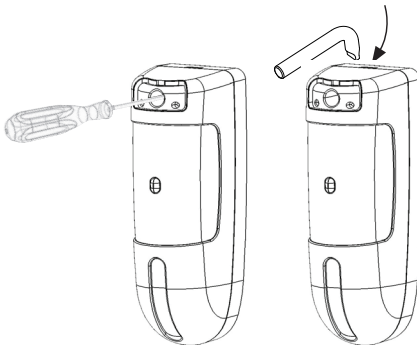

7

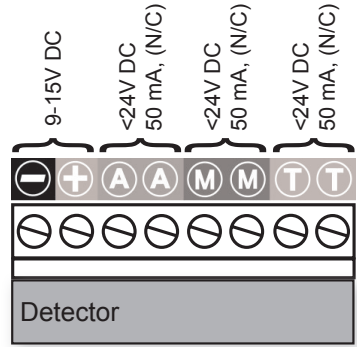

9



11

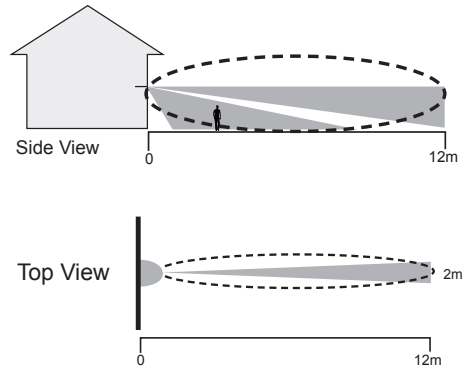

12

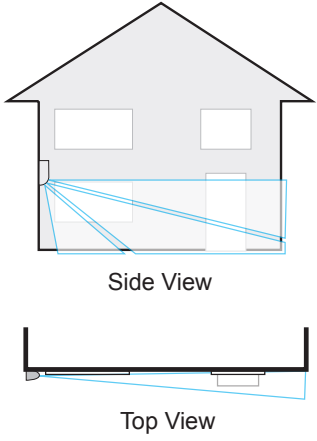

13

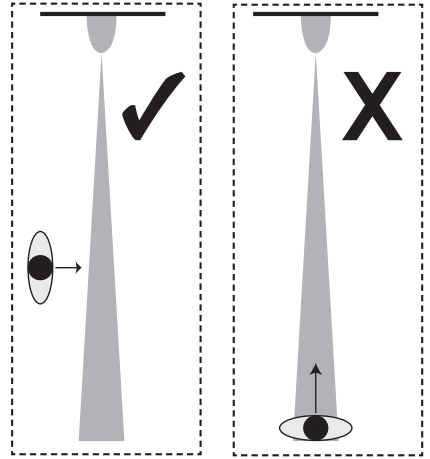

14

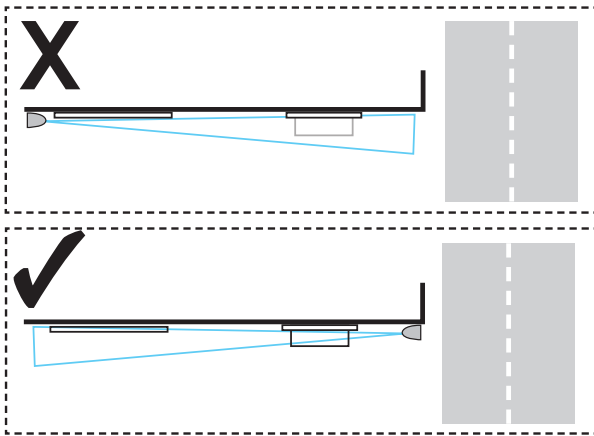

15

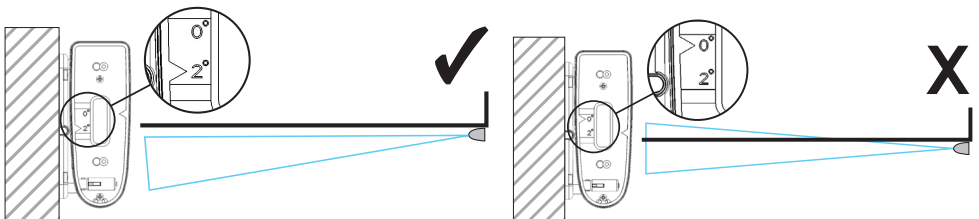

ENGINEER NOTES

www.gjd.co.uk | info@gjd.co.uk | +44 (0) 1706 363 998

Unit 2 Birch Business Park, Whittle Lane, Heywood, Greater Manchester, OL10 2SX, UK