



serverLIFT

[www.serverlift.com](http://www.serverlift.com)

# Operator's Manual

## ***SL-500X<sup>®</sup> / SL-1000X<sup>®</sup>*** **Powered ServerLIFT**

Serial# \_\_\_\_\_

## **NOTICE**

**ONLY ORIGINAL SERVERLIFT  
REPLACEMENT PARTS SHALL BE  
USED FOR ANY REPAIR.**

<b>Introduction</b>	<b>4</b>
Included with SL-500X® or SL-1000X® ServerLIFT	4
<b>Legend</b>	<b>5</b>
<b>Set Up</b>	<b>7</b>
Before you begin	7
Pre-operation Inspection	7
Function Tests	7
<b>Instructions</b>	<b>11</b>
Before operating the ServerLIFT	11
Stabilizer Brake Operation	12
Applying Load To The Platform	13
Front Caster Swivel Lock Operation	13
Safety Directions	14
<b>Accessories</b>	<b>15</b>
LE-500X™/LE-1000X™ Lift Extension	15
RL-500™ Platform Riser	21
RS-500X™ Rail Lift	22
<b>Maintenance</b>	<b>26</b>
Schedule of Maintenance	26
Battery Charging	27
Panel Access Door	28
Testing Battery Charge	28
Battery Replacement	29
Stabilizer Brake Boot Replacement	31
Pulley and Cable Inspection	32
<b>Specifications</b>	<b>33</b>
Features	33
Dimensions and Capacity, SL-500X®	35
Dimensions and Capacity, SL-1000X®	36
<b>Troubleshooting</b>	<b>37</b>
<b>Warranty</b>	<b>41</b>
<b>CE Declaration</b>	<b>43</b>
<b>CE Declaration</b>	<b>44</b>
<b>FCC Declaration</b>	<b>45</b>

**ServerLIFT Corporation**  
17453 N 25th Ave | Phoenix, AZ USA 85023  
(602) 254-1557 | Fax: (602) 412-4479



**Service & Support:**  
[support@serverlift.com](mailto:support@serverlift.com)

**Shipping/Receiving:**  
[shipping@serverlift.com](mailto:shipping@serverlift.com)

**Sales:**  
[sales@serverlift.com](mailto:sales@serverlift.com)

© ServerLIFT Corporation 2017. All Rights Reserved.  
Information in this document subject to change without notice.

06-2017 P/N: SL-1/SL-5 r.C01

## ⚠ CAUTION:

Read and completely understand the contents of this Operator's Manual before operating the ServerLIFT. Failure to read, understand, and follow instructions in this manual may result in property damage and/or personal injury. If you do not understand any part of this manual or if you have any questions please contact ServerLIFT Service & Support.

**IMPORTANT:** Keep these instructions with ServerLIFT.

- Do not stand or ride on any part of the ServerLIFT.
- Never lift or move the ServerLIFT with a pallet truck, jack, or forklift. Use the pallet, ramp, and packaging originally received with the unit for transporting it.
- Keep hands, fingers and clothing clear of platform and mast when equipment is in motion.
- To maximize battery life, keep machine charging when not in use. Always disconnect the Power Cord from charging source before use or servicing.

**Never operate the ServerLIFT while charging**

## Included with SL-500X® or SL-1000X® ServerLIFT

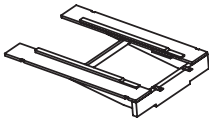

(1) Shipping Ramp

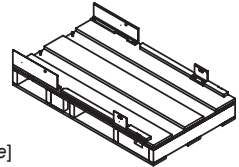

(1) Shipping Pallet  
*[includes retaining hardware]*

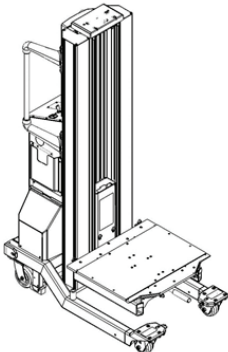

(1) SL-500X® or SL-1000X®



(2) Power Switch Key  
*[keep one key as a spare in a secure location away from ServerLIFT unit]*

(1) Operator's Manual

(1) Canvas Bag for Tie Down Straps

(2) Adjustable Tie Down Strap with hooks

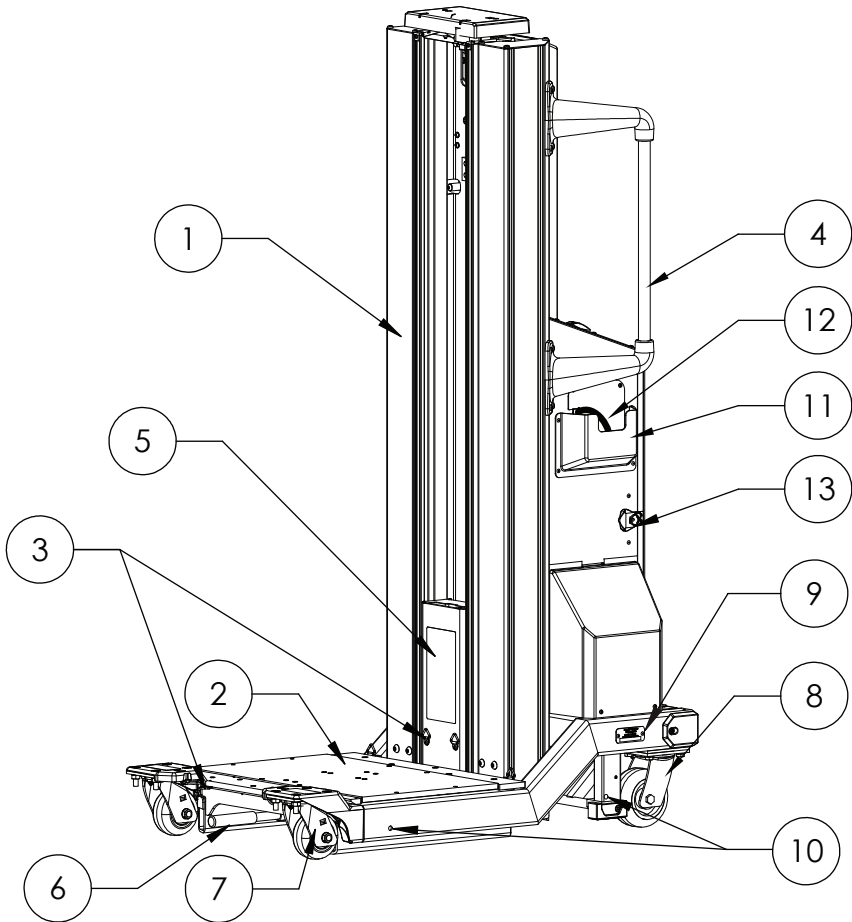

- |  |                             |
|--|-----------------------------|
| 1. Vertical Mast                           | 7. Casters - Swivel/Lock    |
| 2. Equipment Platform and Easy-Glide Shelf | 8. Casters - Free Swivel    |
| 3. Strap Hooks                             | 9. Serial Number Plate      |
| 4. Handle Bars                             | 10. Pallet Bolt Holes       |
| 5. Platform Mast                           | 11. Power Cord Sleeve       |
| 6. Easy-Glide Shelf Handle                 | 12. Power Cord              |
|  | 13. Panel Access Door Latch |

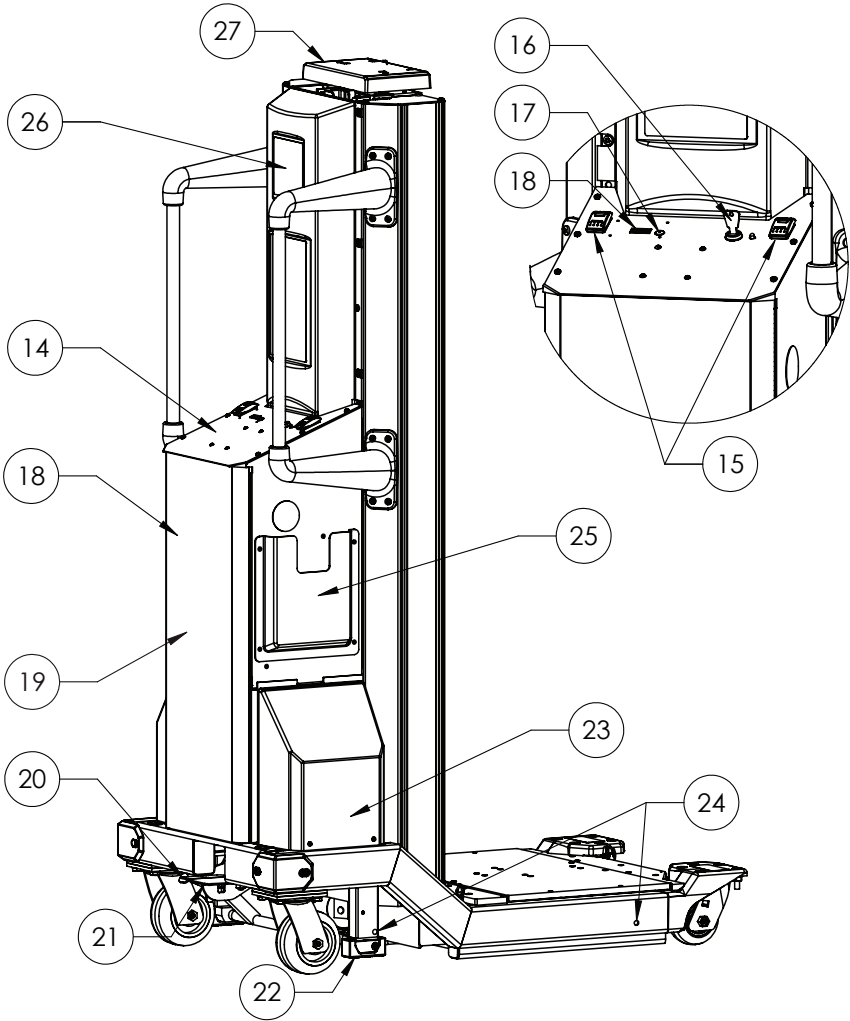

- |                                    |                              |
|------------------------------------|------------------------------|
| 14. Main Control Panel             | 21. Stabilizer Brake Pedal   |
| 15. Up/Down Control Switches       | 22. Stabilizer Brake Pad     |
| 16. Keylock Power Switch           | 23. Winch Cover              |
| 17. Battery Charge Test Button     | 24. Pallet Bolt Holes        |
| 18. Battery Charge Level Indicator | 25. Operator's Manual Sleeve |
| 19. Panel Access Door              | 26. Upper Panel Cover        |
| 20. Stabilizer Brake Release Pedal | 27. TouchSTOP™ Sensor        |

## Before you begin

1. Read and understand the contents of this manual carefully.
2. Locate the serial number plate. Record unit serial number on front page of Operator's Manual for future reference.
3. Perform **Pre-operation Inspection**.
4. Perform **Function Tests**.

## Pre-operation Inspection

Check ServerLIFT for signs of damage. Fully document any damage with photos, location, and description. Promptly contact ServerLIFT Service & Support if any damage is present.

## SAVE PALLET, RAMP, HARDWARE AND PACKING CARTON!

They are needed for moving the ServerLIFT to other locations.

## Function Tests

Function Tests are designed to discover malfunctions before machine is used. Tests should be performed before normal operation. Before testing, select an area that is solid, level and free of obstructions.

⚠ **Note:** *After testing, if malfunctions are discovered, the machine must be locked in OFF status and removed from service. Repairs to the machine may only be made by or under the directions of a service technician qualified by ServerLIFT.*

## Battery Charge

To test battery charge, press Battery Charge Test Button on Main Control Panel, activating Battery Charge Level Indicator.

There are three zones on Charge Level Indicator: DISCHARGED (red), LOW (amber), and FULL (green). If charge level is FULL, the Battery is considered fully charged.

If Battery is not fully charged, recharge it before continuing Set Up (see **Battery Charging**, pg. 27).

➡ **Note: Charge the Battery whenever the ServerLIFT is not in active use to maximize battery life.**

## ⚠ CAUTION

Never plug into a wall outlet or power source that is not approved for your ServerLIFT model. See **Battery Charging**, pg. 27 for approved power source specifications.

**CHARGING BATTERY WITH UNAPPROVED POWER SOURCE OR OPERATING UNIT WHILE CHARGING WILL VOID WARRANTY AND RESULT IN PERMANENT CHARGING SYSTEM FAILURE.**

## **Stabilizer Brake Function Test**

See **Stabilizer Brake Operation** (pg. 12) for additional details.

1. Press down red Stabilizer Brake Pedal so it locks in place. The Stabilizer Brake should remain in DOWN position.

➡ **Note: If operating correctly, engaging the Brake will very slightly lift the back of the ServerLIFT up off the ground. Applying additional force may be required to engage the Stabilizer Brake at the point where it lifts the unit and locks in place. If too much force is needed, or the Stabilizer Brake does not lift the back wheels up, contact ServerLIFT Service and Support.**

2. Attempt to move the ServerLIFT. It should be locked in place and not be able to move. If it rolls at all, or Stabilizer Brake does not lock in DOWN position, contact ServerLIFT Service and Support.
3. To release, press green release pedal and allow pedals to return to UP positions.
4. If operating correctly, proceed to next Function Test.



## **Winch Motor Function Test**

1. Engage the Stabilizer Brake.
2. Turn unit power on by inserting key and turning clockwise to **ON** ( - ) position.
3. Press Up/Down Control Switch to move Platform **UP**. Test full range of motion up and down. Platform will automatically stop in fully extended and fully retracted positions. If Platform does not travel full range of motion consistently, contact ServerLIFT Service and Support.

➡ **Note: Clicking or ratcheting noises are normal when raising/lowering Platform.**

### **⚠ WARNING**

Platform Mast extends higher than Platform. When raising Platform, be aware of ceiling height, cable trays, sprinklers, lights, and other overhead obstructions.

4. Repeat step 2 with second Up/Down Control Switch. As Platform Mast extends above the Vertical Mast, press TouchSTOP™ Sensor above Platform Mast while continuing to raise Platform. Platform should stop. Release TouchSTOP™ Sensor. Platform should only resume motion when Up/Down Control Switch is released and pressed again. If TouchSTOP™ Sensor does not stop Platform when depressed or operate as described herein, contact ServerLIFT Service and Support.

➡ **Note: TouchSTOP™ Sensor will not stop Platform motion before Platform Mast extends above Vertical Mast.**

## **Easy-Glide Shelf Function Test**

1. Engage Stabilizer Brake.
2. Turn unit power on by inserting key and turning clockwise to **ON** ( - ) position.
3. Raise Platform above casters to a comfortable working height.

4. Push down on handle to unlock and allow movement of Easy-Glide Shelf. Shelf will shift sideways up to 6" (15cm) in each direction. There are four (4) incremental adjustment locations: Two right of center, and two left of center.
5. Test full movement of Easy-Glide Shelf in both directions. If shelf does not travel entire range of motion consistently or does not lock at incremental adjustment locations, contact ServerLIFT Service and Support.
6. Return Shelf to neutral (center) position.
7. Lower Platform down. Turn off unit power by turning key to **OFF** ( **O** ) position. Release Stabilizer Brake.

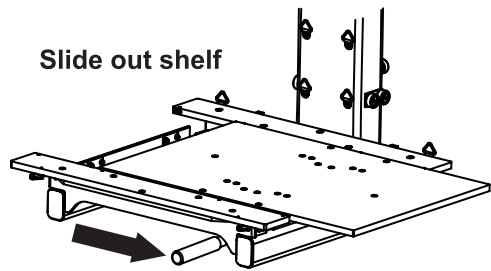
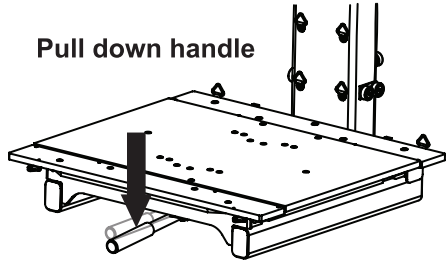

**⚠ DANGER**

**NEVER raise or lower platform with shelf out of neutral (center) position.**

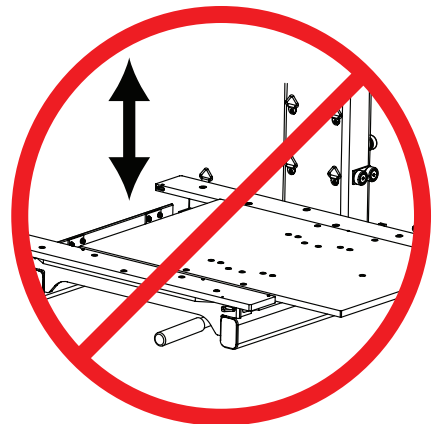

## Before operating the ServerLIFT

1. Read and understand the operating steps and functions well.
2. Remove any objects or obstructions around or under the ServerLIFT, or in travel area of Platform.
3. Make sure Battery is fully charged.
4. Make sure Stabilizer Brake engages and locks in place. Both Stabilizer Brake Pads must be installed and engage floor correctly (see **Stabilizer Brake Operation** on pg. 12).

## ServerLIFT Operating Steps

1. Position the ServerLIFT unit
2. Engage Stabilizer Brake
3. Power the ServerLIFT unit **ON** ( - )
- ⚠ 4. Adjust Platform to desired loading height
- ⚠ 5. Load equipment onto Platform
6. Secure equipment using Adjustable Tie Down Straps\*
- ⚠ 7. Lower Platform to lowest position
8. Power the ServerLIFT unit **OFF** ( O )
9. Release Stabilizer Brake
10. Move the ServerLIFT unit to destination
11. Engage Stabilizer Brake
12. Power the ServerLIFT unit **ON** ( - )
- ⚠ 13. Raise platform to desired unloading height
- ⚠ 14. Load equipment from Platform and Easy-Glide Shelf into rack
- ⚠ 15. Lower Platform to lowest position
16. Power the ServerLIFT unit **OFF** ( O )
17. Release Stabilizer Brake
18. Charge ServerLIFT when not in use

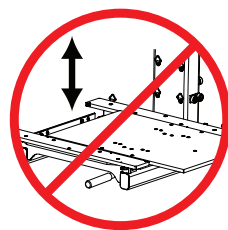

**⚠ DANGER**  
**NEVER raise or lower platform with shelf out of neutral (center) position.**

*\* especially critical when moving the ServerLIFT unit across uneven or not level ground*

## Stabilizer Brake Operation

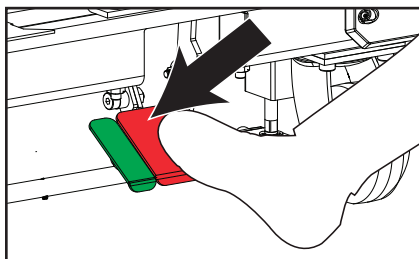

To engage Stabilizer Brake, depress red pedal until it locks in **DOWN** position. The back of the ServerLIFT unit should slightly lift up off the ground. The ServerLIFT unit should not move. If ServerLIFT unit moves, the Stabilizer Brake is not

functioning properly. Contact ServerLIFT Service and Support.

⚠ **Note:** *Without equipment on the platform, average force is all that is needed to fully depress Stabilizer Brake. The force required will increase as equipment/weight is added to the platform.*

Once Stabilizer Brake is locked in **DOWN** position, ServerLIFT unit is stabilized, parked and ready for use. Follow Operating Steps 3-8 or 12-16 (pg. 11).

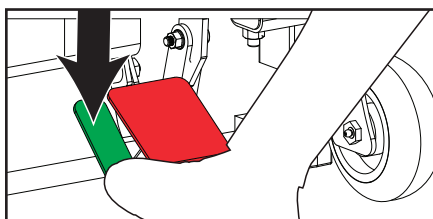
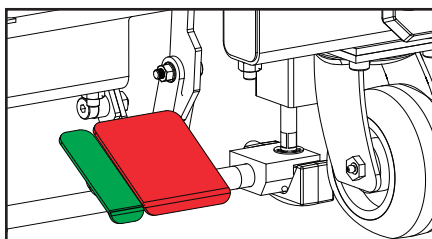

Press on green release pedal until unlocked and slowly pull foot back allowing both pedals to fully retract.

### **⚠ WARNING**



- Always engage Stabilizer Brake before raising, lowering, or sliding Easy-Glide Shelf
- Engage Stabilizer Brake whenever ServerLIFT is not in motion
- ServerLIFT will/should not move with Stabilizer Brake engaged



## Applying Load To The Platform

**⚠ WARNING**

NEVER place more than the maximum load on edge of Platform Shelf. The maximum rated load at the edge is reduced when the Platform Shelf is extended.

NEVER raise or lower platform with shelf out of neutral (center) position

<b>⚠ WARNING</b>		
	<b>SL-500X® MAX. LOAD</b>	<b>500 lbs (227 kg)</b>

<b>⚠ WARNING</b>		
	<b>SL-1000X® MAX. LOAD</b>	<b>1000 lbs (454 kg)</b>

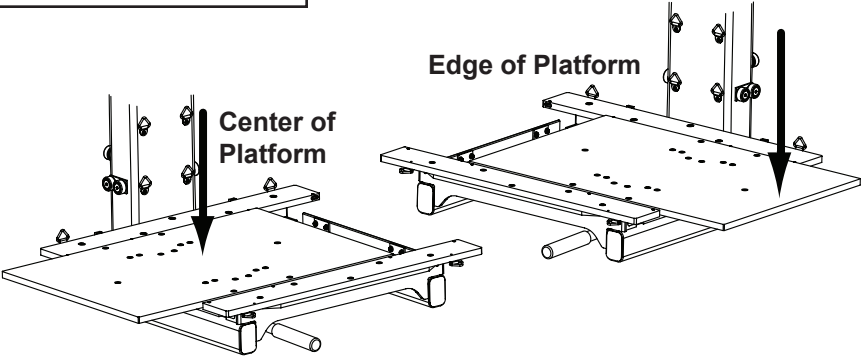

## Front Caster Swivel Lock Operation

### UNLOCKED

To unlock Front Caster, pull out ring and turn 90 degrees in either direction. Allow ring to align in vertical groove as shown.

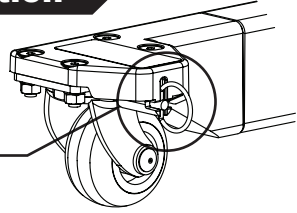

### LOCKED

To lock Front Caster, pull ring out and turn 90 degrees in either direction. Allow ring to align in horizontal groove as shown. Ensure caster is in line with base frame arm and pointing backward. An audible click indicates the lock is engaged.

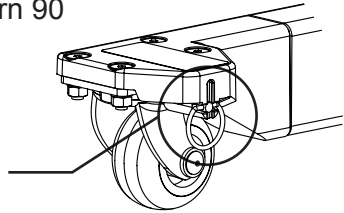

## Safety Directions

### Fall Hazards

- Do not stand on any part of lift.
- Do not climb on mast.
- Do not use as a personnel lifting platform or step.

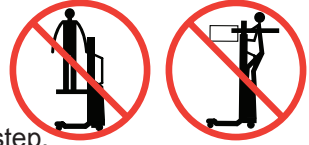

### Tip-over Hazards

- Do not lift load unless stabilizer is fully engaged.
- Do not move machine while platform is raised, except for minor positioning.
- Only raise load if properly centered on platform.
- Do not operate while under the influence of drugs or alcohol.
- Do not stand under overhanging load.
- Do not exceed rated load capacity.
- Do not stack loads.
- Do not support ladder against ServerLIFT.
- Do not use on uneven or graded surface



### Collision Hazards

- Only lower load in areas clear of personnel and obstructions.
- Platform Mast extends higher than Platform. Be aware of ceiling height, cable trays, sprinklers, lights, and other overhead objects.

### Damaged Machine Hazard

- Do not operate a damaged or malfunctioning ServerLIFT.



### Improper Use Hazard

- Do not leave machine unattended with an elevated load.
- Do not raise or lower platform with shelf out of neutral (center) position OR with handle not retracted.



### Pinch Point Hazard

- Keep hands clear of moving parts and open sections during operation.
- Hands should only be on handle bars and/or on designated locations needed for operation.



## LE-500X™/LE-1000X™ Lift Extension

The ServerLIFT LE-Series Lift Extensions are accessories that assist in lifting heavy IT equipment out of boxes and off of skids. They feature a lightweight design that is capable of lifting up to 500lb (227kg) or 1000lb (454kg) respectively. The LE-500X™ may be used with the SL-500X® ServerLIFT and the LE-1000X™ may be used only with the SL-1000X® ServerLIFT.

### **⚠ WARNING**

- Do not stand or ride on any part of Lift Extension.
- Do not exceed the maximum load.
- Do not operate with a load that has a center of mass placed forward (away from the ServerLIFT) of indicated Lift Extension Load Center.

**NEVER USE THE LE-500X™ OR LE-1000X™ LIFT EXTENSIONS WITHOUT SWING ARM HOOK ENGAGED OVER LIP OF PLATFORM MAST**

### **Included with LE-500X™ or LE-1000X™ Lift Extension**

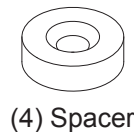
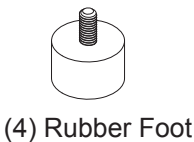
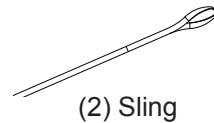
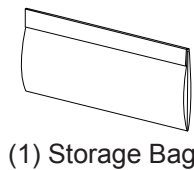
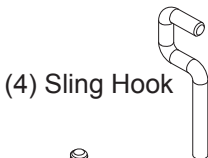
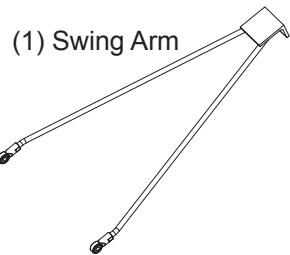
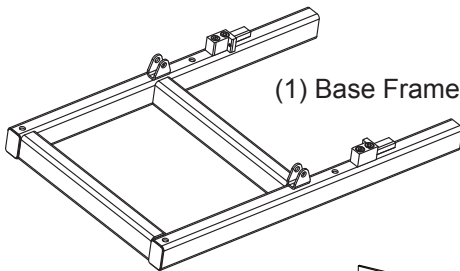

## Setting Up the LE-Series Lift Extension

ⓘ **Note:** Proper setup, installation, and use of this product is the sole responsibility of the installer.

1. Assemble Sling Hook into Spacer and insert completely through frame hole from the top as shown.
2. Screw Rubber Foot into bottom of Sling Hook. Repeat steps 1 and 2 in remaining three hook locations as shown.
3. Insert Swing Arm into both pivot brackets as shown.
4. Secure Spherical Rod Ends of Swing Arm to pivot brackets with Locking Pins.

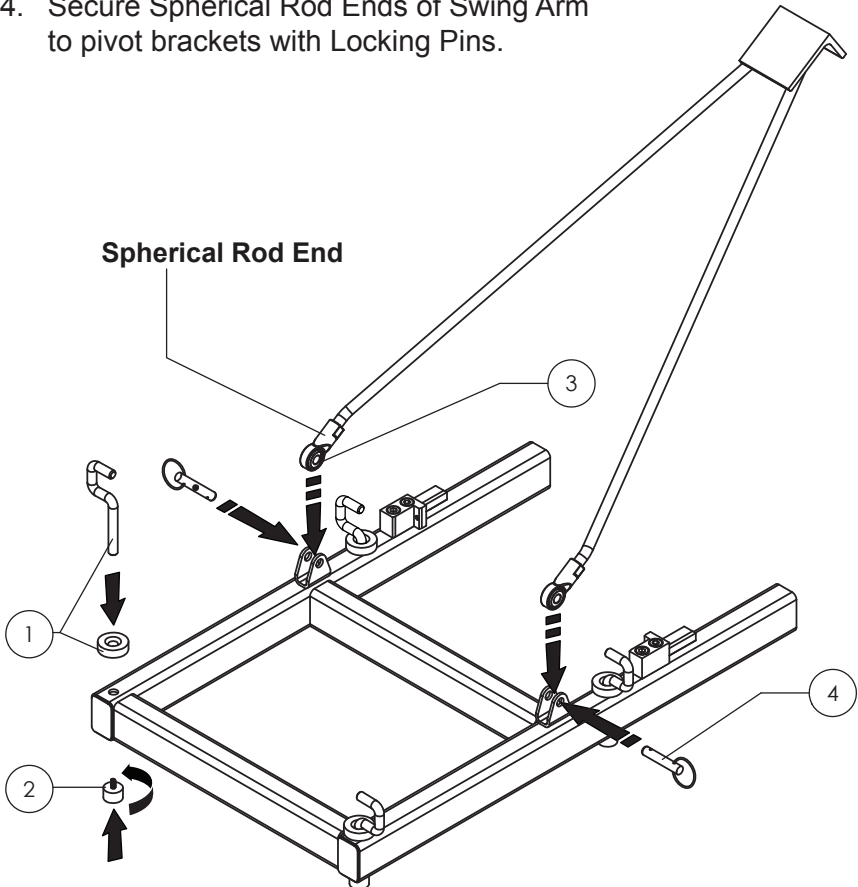



## Attaching Lift Extension to the ServerLIFT

1. Engage ServerLIFT Stabilizer Brake and turn power ON.
2. Raise Platform to a height of at least 1.5ft (0.5m) above Caster Wheel mounts.

3. With Swing Arm rotated towards closed end of Lift Extension Frame, insert Lift Extension into ServerLIFT Platform Frame as shown. Extension Catches should insert into Platform Frame tubes with top of Lift Extension Frame Arms resting against underside of the Platform Frame tubes.

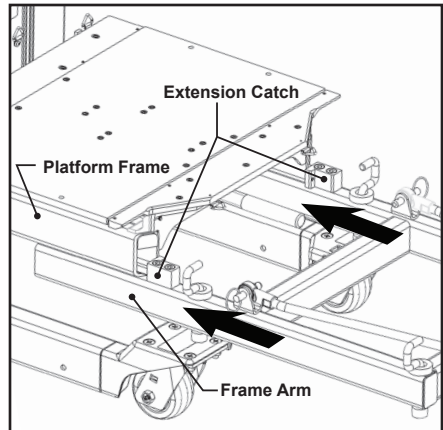

### **⚠ WARNING**

**Catches must be fully inserted into Platform Frame**

4. Rotate Swing Arm until its hook engages over the Platform Mast top lip.

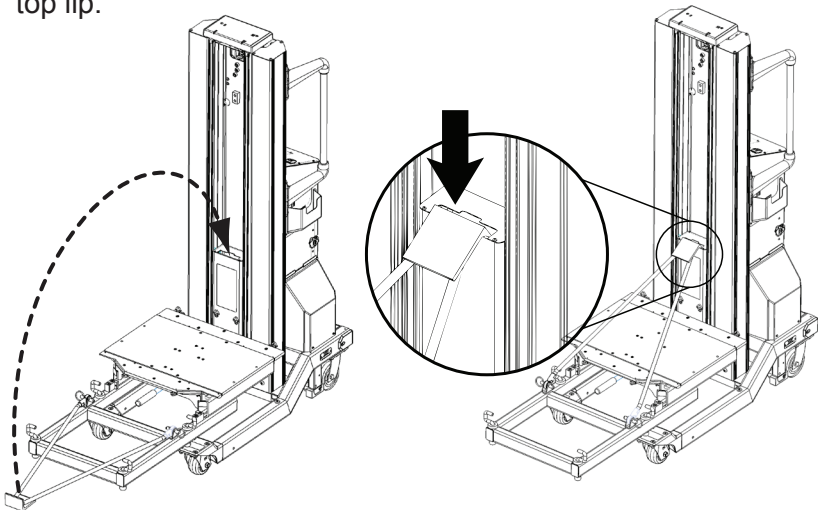

## **⚠ DANGER**

**Swing Arm MUST be engaged with Platform Mast before use. Using Lift Extension without Swing Arm engaged may cause death or serious injury.**

### **Adjusting the Swing Arm**

Adjustments may be necessary to ensure proper engagement.

If Swing Arm Hook goes too far over lip of Platform Mast, it is over-engaged. To adjust Swing Arm based on over-engagement:

1. Engage ServerLIFT Stabilizer Brake and turn power ON.
2. Raise Platform to a height of at least 1.5ft (0.5m) above Caster Wheel mounts.
3. Use a 3mm hex wrench to screw each Adjustment Screw equally inward (toward Platform) to create separation between Catches and Platform Frame. This increases engagement of Swing Arm Hook.

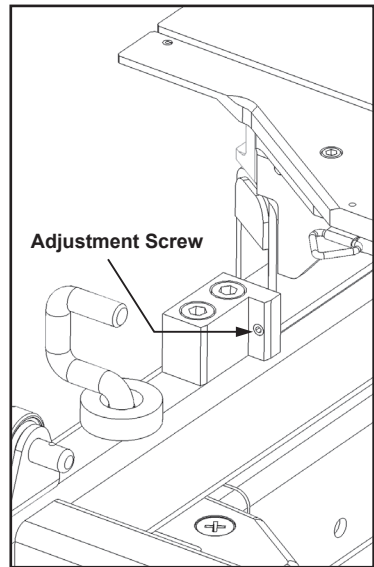



If Swing Arm Hook does not go easily over lip of Platform Mast, it is under-engaged. To adjust based on under-engagement:

1. Ensure that Adjustment Screws are completely loosened.
2. Make sure Lift Extension is fully inserted into Platform Frame. Front surface of Catches should touch Platform Frame.
3. If Swing Arm Hook is still under-engaged, remove Lift Extension from ServerLIFT.

4. Remove Locking Pins, and disassemble Swing Arm from Lift Extension.
5. Lengthen Swing Arm by rotating each Spherical Rod End counterclockwise (with Rod Ends facing you and Hook end facing away from you) one full turn (360 degrees).
6. Reassemble Swing Arm and Lift Extension with Locking Pins.
7. Re-attach Lift Extension to ServerLIFT and engage Swing Arm. If it is still under-engaged, repeat steps 3-7.

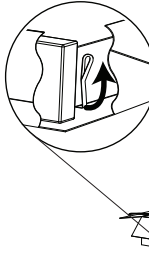
## **Using the LE-Series Lift Extensions**

1. Hook loop end of one yellow Sling on to rear Sling Hooks of one side of the LE-Series (LE-500X™ or LE-1000X™) Lift Extension.
2. Feed the loose end of the Sling from back to front under IT equipment while in it's box.
3. Hook loose loop end of the Sling to the front Sling Hook on the same side of the LE-Series Lift Extension.
4. Repeat with the second Sling on the other side of the LE-Series Lift Extension.

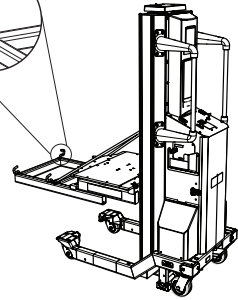

### **⚠ CAUTION**

**Center of gravity of the load must be centered in between Sling Hooks.**

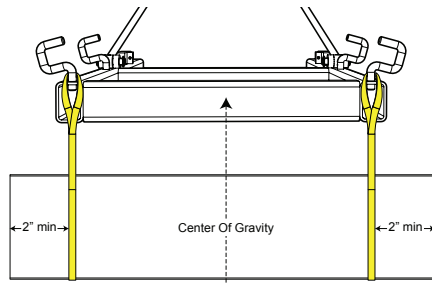

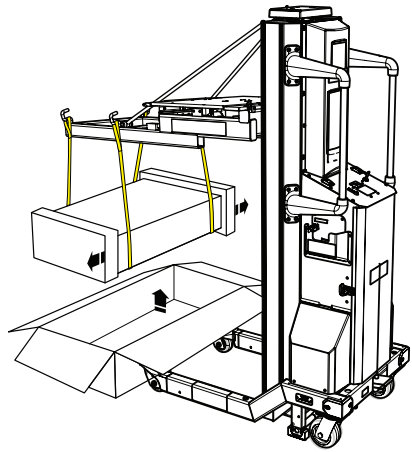
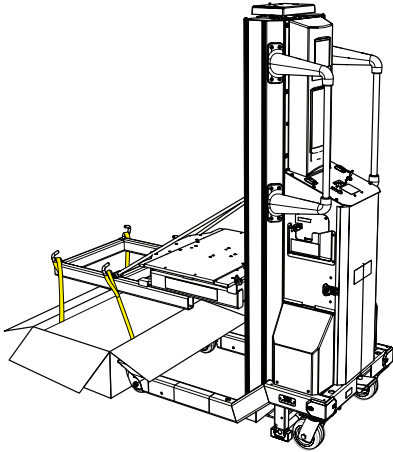

1. Lift equipment out of box and remove packaging.
2. Lower equipment down onto a table or secure surface.

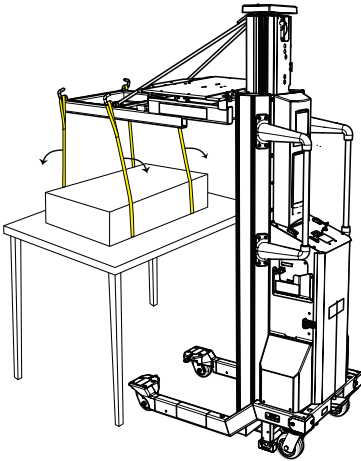

3. Remove yellow Slings from Sling Hooks.

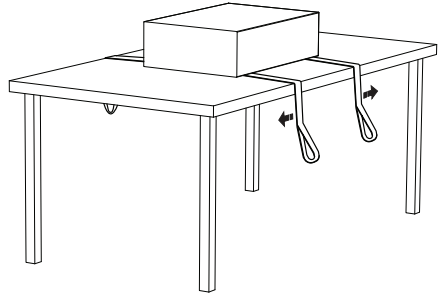

4. Remove slings from under equipment.

5. Disengage Swing Arm, remove Lift Extension from SL-500X® or SL-1000X® ServerLIFT, and safely set aside Lift Extension.
6. Slide equipment from table onto ServerLIFT Platform and Easy-Glide Shelf and follow Operating Steps 5 - 17 (pg. 11).

## RL-500™ Platform Riser

The ServerLIFT RL-500™ Platform Riser accessory enables users to install servers at the top of any rack in areas where equipment positioning is a challenge. These situations include:

- Low ceilings clearance or obstructions
- Cold and hot aisle containment rooms
- Ten foot (3 meter) tall racks
- Drop in rails

The ServerLIFT RL-500™ Platform Riser features a lightweight yet rugged design, and is compatible with all current and past models of ServerLIFTS.

### Included with the RL-500™ Platform Riser

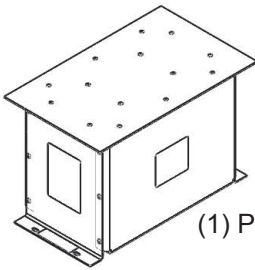

(1) Platform Riser

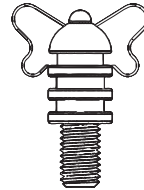

(4) Thumbscrew

### **⚠ WARNING**

- Do not stand or ride on any part of Platform Riser.
- Do not exceed the maximum load of 500 lbs (227 kg).
- Do not use together with LE-500X™ or LE-1000X™ Lift Extensions or PL-500X™ Platform Extension.
- No corner load.

**SECURE PLATFORM RISER TO SERVERLIFT SHELF IN ALL FOUR LOCATIONS (WITH PROVIDED HARDWARE ONLY) PRIOR TO USE**

## **Attaching Platform Riser to the ServerLIFT**

1. Engage ServerLIFT Stabilizer Brake.
2. Place Platform Riser onto ServerLIFT Easy-Glide Shelf. Line up slotted holes in bottom flanges of Platform Riser with threaded holes on ServerLIFT Easy-Glide Shelf.
3. Secure Platform Riser to Shelf with Thumbscrews and Washers in all four locations as shown.

### **⚠ WARNING**

**Platform Riser must be secured in all four locations**

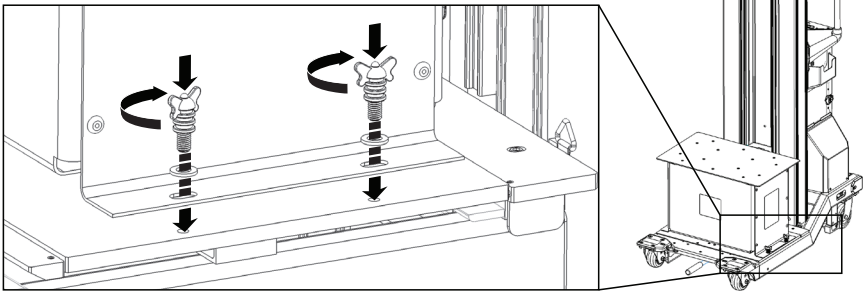

ⓘ **Note:** Platform Riser should be removed and set aside when not in use. Four holes on Platform Riser top plate are provided for convenient storage of Thumbscrews and Washers when not in use.

## **RS-500X™ Rail Lift**

The ServerLIFT RS-500X™ Rail Lift accessory enables users to position and support servers at an angle for installation or removal from slotted or drop-in rails.

The ServerLIFT RS-500X™ Rail Lift features a low profile yet rugged design, and is compatible with all current and past models

of ServerLIFTS. Its convenient, multi-hinged crank handle can be used to adjust the angle of the equipment surface from flat level up to 5° of angled position.

The ServerLIFT RS-500X™ Rail Lift can be secured to the ServerLIFT Platform Shelf in one of two positions, allowing the Operator the choice of using it from the left or right side of the SL-500X® or SL-1000X® ServerLIFT. The RS-500X™ Rail Lift can also be used in conjunction with the RL-500™ Platform Riser.

## **Included with the RS-500X™ Rail Lift**

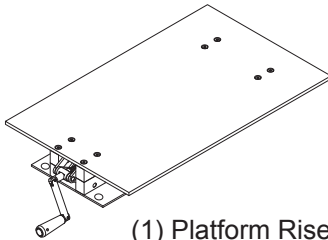

(1) Platform Riser



(4) Thumbscrew

### **⚠ WARNING**

- Do not stand or ride on any part of Rail Lift.
- Do not exceed the maximum load of 500 lbs (227 kg).
- Do not use together with LE-500X™ or LE-1000X™ Lift Extensions or the PL-500X™ Platform Extension
- No corner load.

**SECURE RAIL LIFT TO SERVERLIFT SHELF  
IN ALL FOUR LOCATIONS (WITH PROVIDED  
HARDWARE ONLY) PRIOR TO USE**

## **Attaching to ServerLIFT or RL-500X™ Riser**

1. Engage ServerLIFT Stabilizer Brake.
2. If installing onto the Platform Riser, ensure that the RL-500™ Platform Riser is attached and secured to the ServerLIFT Easy-Glide Shelf per the directions on page 22.

1. Place the RS-500X™ Rail Lift onto ServerLIFT Easy-Glide Shelf or RL-500™ Platform Riser. Line up the four holes in the base plate of Rail Lift with threaded holes on ServerLIFT Easy-Glide Shelf or RL-500™ Platform Riser.
2. Secure the RS-500X™ Rail Lift to Shelf with Thumbscrews in all four locations as shown below.

**⚠ WARNING**  
**Rail Lift MUST**  
**be secured in all**  
**four locations**

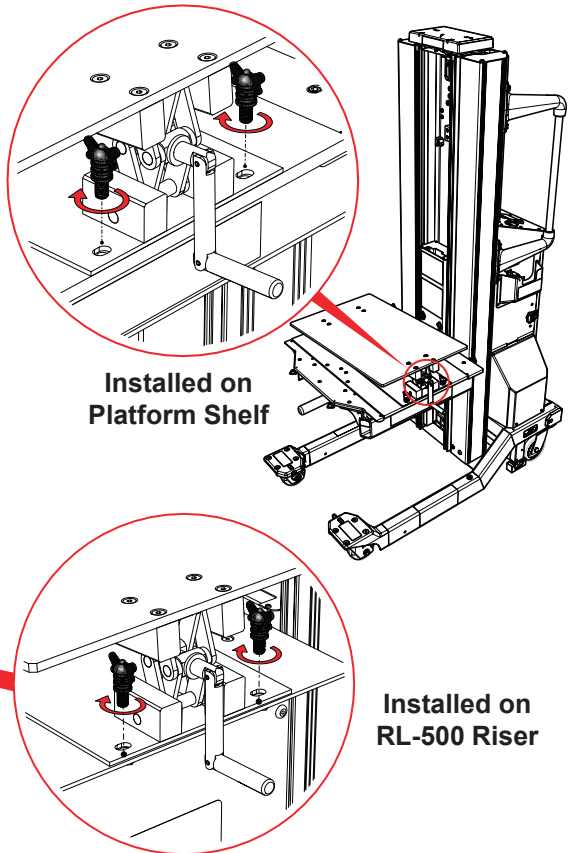

Installed on  
Platform Shelf

Installed on  
RL-500 Riser

## **Using the Rail Lift**

1. Ensure that the RS-500X™ Rail Lift is attached to the Easy-Glide Shelf or the RL-500™ Platform Riser as needed per the above directions.



2. Follow Operating Steps 1 - 13 on page 11.
3. For installs, raise platform to a height where the equipment nailheads are just above the installation rails.
4. Shift Easy-Glide Shelf towards the rack and rails. Extend the rails out to line up with nailheads.

5. Angle Equipment using Rail Lift by rotating the handle so the nailhead closest to the rack is positioned just above the slot.

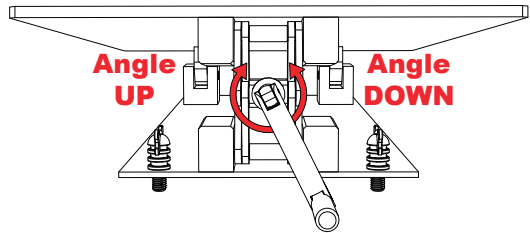

6. Lower Platform so the first nailhead lowers into its slot.
7. Guide the other nailhead(s) into their corresponding rail slot(s) using the RS-500X™ Rail Lift by rotating the handle to reduce the equipment angle.



8. Once all nailheads are lined up in their respective rail slots, lower the Platform so equipment is fully supported by the rails. Reverse these steps for un-racking server equipment.

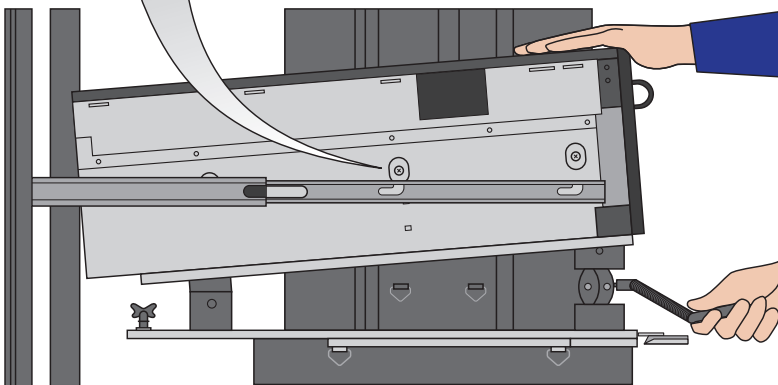

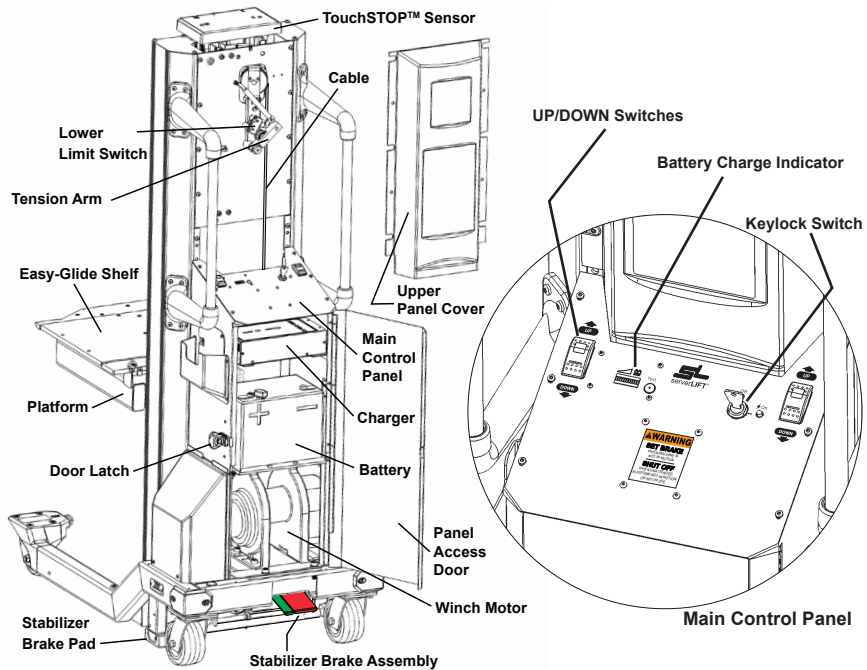

## Schedule of Maintenance

Activity	Required Frequency
Charge Battery	Daily (whenever unit not in use)
Replace Battery	As needed
Replace Stabilizer Brake Pads	As needed
Inspect Winch Cable	Every 12 months
Inspect Pulleys	Every 12 months
Flush and Change Winch Oil*	Every 12 months (suggested)*

\* Oil replacement kits and directions are available from ServerLIFT Service & Support.



➡ **Note:** Units covered under optional Extended Warranty and Service contracts have all above maintenance checks (except for battery replacement) performed as part of ServerLIFT's annual service visit.

## Battery Charging

Both the ServerLIFT SL-500X® and SL-1000X® are equipped with a rugged, compact and sophisticated three-state battery charger that recharges the onboard 12V 80Ah VRLA battery. The charger is automatic and simply needs to be plugged in to a suitable power supply or standard wall outlet.

Depending on unit model, the ServerLIFT SL-500X® and SL-1000X® may be equipped for 110V or 220V service. This is indicated above the power cord on the side of the ServerLIFT. The configuration and electrical requirements of each model are as follows:

	<b>SL-500X® SL-1000X®</b>	<b>SL-500XI® SL-1000XI®</b>
<b>Indicated Voltage</b>	110V	220V
<b>Voltage Input Range</b>	90-132VAC	180-250VAC
<b>Max. Frequency Input</b>	50/60 Hz	50/60 Hz
<b>Max. Current Input</b>	4A rms	1A rms
<b>Cord termination</b>	6ft grounded AC	15cm grounded AC
<b>Cord-end/plug style</b>	Type B NEMA 5-15 (3-pin, male)	C14 inlet receptacle (3-pin, male)

<b>NOTICE</b>	 <b>DANGER</b>
<b>KEEP CHARGING WHEN NOT IN USE TO MAXIMIZE BATTERY LIFE</b>	 <b>UNPLUG BEFORE OPERATING OR SERVICING</b>

### **WARNING:**

- **NEVER** plug into an outlet with service outside model Voltage Input Range. Charger failure will result.
- **NEVER** operate a charger with a damaged cord or plug.
- When using an extension cord, a quality grounded cord of at least 16 AWG wire size (cords up to 50'/15m) is required.

## Panel Access Door

### Opening

1. Flip Latch Tab up towards door.
2. Rotate counterclockwise until latch separates from Door Keeper Plate.
3. Flip entire latch assembly up away from door.
4. Open Panel Access Door.

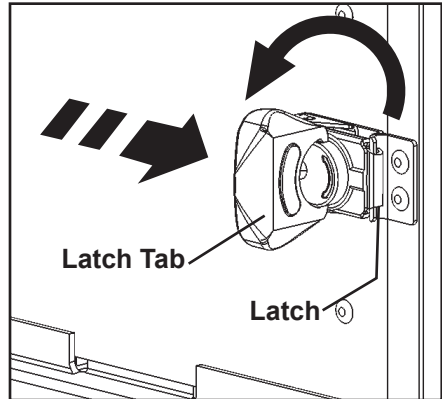

### Closing

1. Close Panel Access Door.
2. Flip entire latch assembly down towards door until it covers Door Keeper Plate.
3. Rotate Latch Tab clockwise until Latch engages Door Keeper Plate.
4. Flip Latch Tab down.

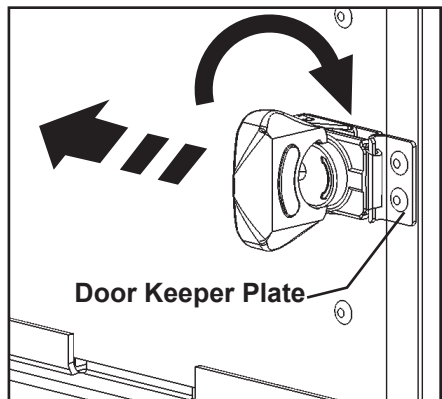

## Testing Battery Charge

### Automatic/Quick Test

1. Make sure Power Cord is unplugged.
2. Press Battery Charge Test Button on Main Control Panel, activating Battery Charge Level Indicator.
3. There are 3 charge zones on Level Indicator: DISCHARGED

(red), LOW (amber), and FULL (green). If charge level is FULL, the Battery is considered fully charged.

4. If Battery is not fully charged, charge for 12 – 48h depending on how low of a charge is indicated (very low charges require much longer charging times).
5. If Battery will not hold a charge, or if you suspect false results from Battery Charge Level Indicator and Battery may need to be replaced, a manual battery charge test is recommended.

## **Manual Test**

1. Make sure Power Cord is unplugged.
2. Open Panel Access Door.
3. Apply positive lead of a handheld voltmeter to positive (red) battery terminal and negative voltmeter lead to negative (black) battery terminal.
4. Read voltage. Fully charged batteries show 11.8 – 13V. Batteries reading 11V or less after 12 - 48h of charging should be replaced.
5. Close the Panel Access Door.

### **⚠ WARNING:**

- **ALWAYS** unplug Power Cord before testing Battery charge.
- Testing Battery charge with Power Cord plugged in will yield false results.

## **Battery Replacement**

The SL-500X® and SL-1000X® ServerLIFT's use an onboard low-maintenance, VRLA (valve-regulated lead-acid), AGM (Absorbed glass mat) battery. It is sealed and spill-proof. Replacements are commonly available from suppliers of high performance marine or UPS style batteries, or directly through ServerLIFT Service & Support. Bring old Battery with you to supplier for comparison and safe disposal.

Construction	Nominal Voltage	Nominal Capacity	Terminal Type
ABS Plates AGM Separator	12 Volt	75 or 80 Ah	Internal
Length	Width	Height	Weight
10.20" 260mm	6.61" 168mm	8.43" 215mm	52.53lb 23.83kg

ⓘ **Note:** *ONLY batteries with INTERNAL terminals will fit inside the ServerLIFT SL-500X® and SL-1000X®. Batteries with external terminals will not work and may cause fire or explosion.*

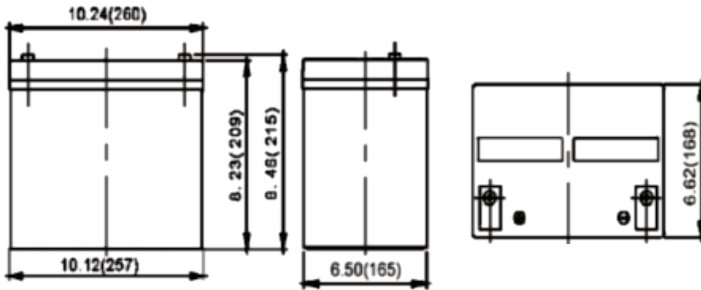

1. Open Panel Access Door.
2. A zip-tie installed to hold the Battery in place during shipping may be holding it in place. Cut or remove zip-tie. Zip-tie does not need to be replaced.
3. Pull red Battery Quick Disconnect out from its mate.
4. Remove Battery and Quick Disconnect wire assembly from shelf.

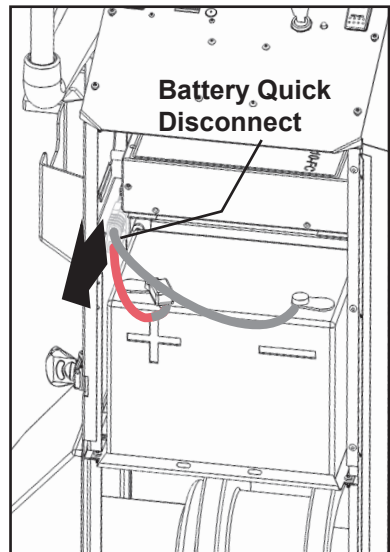

ⓘ **Note:** *Remove with care – Batteries weight 52lb (23.5kg)*

5. Loosen and remove terminal post from positive (red) battery terminal. Keep the post and all washers. Keep circuit breaker/wire/disconnect assembly intact.

⦿ **Note: In-line circuit breaker only required for red terminal.**

6. Repeat step 5 for negative (black) battery terminal.
7. Connect circuit breaker end of Battery Quick Disconnect assembly to positive (red) terminal of new battery with post and washers. Ensure post is screwed on tightly.
8. Connect ring terminal end of Battery Quick Disconnect assembly to negative (black) terminal of new battery with post and washers. Ensure post is screwed on tightly.
9. Carefully put new Battery into place on shelf.
10. Insert red Battery Quick Disconnect receptacle to its mate, located on inside of panel enclosure.
11. Close Panel Access Door.
12. Verify ServerLIFT is receiving power from new Battery by turning it **ON** and cycling Platform up and down. Check that Battery Charge Level Indicator shows FULL when tested.

## Stabilizer Brake Boot Replacement

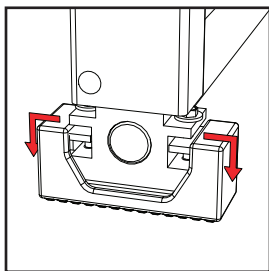

Removal

1. Pull top corners of old boot out and down to remove from Stabilizer Brake Pad.
2. Press new boot on until it snaps in to place.

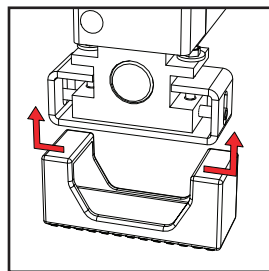

Installation

## Pulley and Cable Inspection

### Cable Inspection

1. Fully lower platform and inspect upper cable section.
2. Open Panel Access Door. Fully cycle Platform up and down while inspecting section of cable winding onto the winch motor.
3. When inspecting cable, look for:
  - **Wear or Corrosion**
  - **Broken wires or cut strands**
  - **Distortion, kinking, uneven strands, crushed parts, uneven cable diameter, or strands coming off**

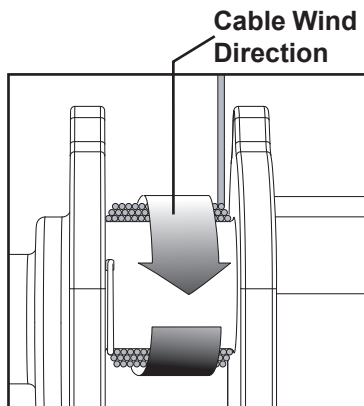

Discontinue use of ServerLIFT if any cable damage is discovered upon inspection, and contact ServerLIFT Service & Support immediately. Do not attempt to repair or change cable.

### Pulley Inspection

When inspecting pulleys, listen for squeaking, look for cracks, extreme wear, loose connections, and bent/damaged pulley guards.

➡ **Note: Bent or damaged pulley guards WILL interfere with cable operation. DO NOT attempt to operate with damaged pulleys.**

1. Remove Upper Panel Cover. Inspect Tension Switch Pulley.
2. From front of the machine, inspect Upper Pulley.
3. Inspect Lower Pulley from undercarriage of the ServerLIFT.

➡ **Note: Lower Pulley only be visible from undercarriage when Platform is completely lowered.**

If inspection reveals any pulley irregularities or damage, discontinue use of ServerLIFT and contact ServerLIFT Service & Support immediately.



## Features

### **Compact Design**

- Slim 24" (61cm) base easily navigates narrow aisles
- 4 oversized swivel casters for tight maneuvering and protection of raised floor tiles
- Swivel locks in front engage when straight tracking is required
- Fits through standard doorways
- Ideal for cold aisle containment rooms
- Overall heavy duty steel and aluminum construction
- Reusable packaging included for location transfers

### **Fully Contained**

- Non-hydraulic heavy duty winch motor
- Powered by a rechargeable deep-cycle, AGM leak-proof/sealed (AGM), 12V VRLA battery
- Safe for data center floors

### **Heavy Duty Platform**

- Minimal to no deflection or sagging even under full load
- Precise equipment alignment
- Included tie-down straps secure equipment during moves

### **Side-Loading Usability**

- Load equipment while parallel to the rack
- Eliminates any obstruction of operator's view
- Easy alignment facing the rack

### **Easy-Glide Shelf**

- 6" (15.25cm) left or right lateral movement for supported loading
- Fits into standard 19" (48.25cm) racks
- Pull-out/retractable handle
- Seamless install from the platform into the rails

### **Smart Controls**

- Precise height adjustment with proprietary microprocessor-controlled lifting system
- Dual side controls allow single operator to align equipment while facing the rack

## **Telescoping Mast**

- SL-500X® Lift 500lb (226kg) to 8' or 2.45m
- SL-1000X® Lift 1000lb (452kg) to 9' / 2.76m
- Quickly raise equipment to the top of travel in under 1 minute

## **TouchSTOP™ Sensor**

- Proprietary sensing technology cuts power to machine on contact with ceiling, lights, cable trays, or other overhead obstructions
- Safety feature prevents equipment damage and injuries
- Enables safe use in contained and open environments without any modifications or adjustments

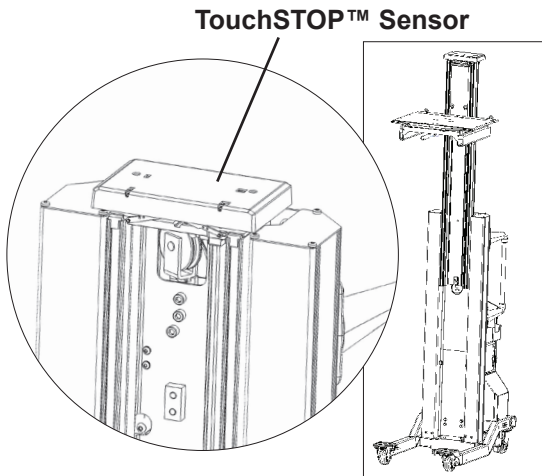

## **Locking Stabilizing Brake System**

- Prevents unit from moving during installation
- Increases side-to-side stability

## **Safe Operation**

- Eliminates manual lifting of equipment
- CE certified and FCC/IC classified
- Built-in solid state battery charger
- Cord management sleeve
- Secure key lock switch allows power lock-out of device when not in use or during loading to prevent accidents.
- Automatic safety stops in maximum upper and lower positions

# Specifications

www.serverlift.com

## Dimensions and Capacity, SL-500X®

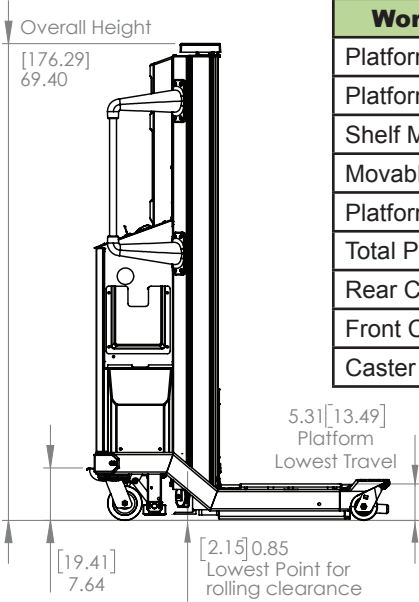

Working Dimensions	US	Metric
Platform Height, Extended	8.0'	2.44m
Platform Height, Lowered	5.3"	13.5cm
Shelf Movement per side	6.0"	15.2cm
Movable Platform Width	14.6"	36.8cm
Platform Width	24"	61.0cm
Total Platform Depth	21"	53.0cm
Rear Caster Wheel Diameter	5"	12.7cm
Front Caster Wheel Diameter	4"	10.2cm
Caster Wheel Width	2"	5.08cm

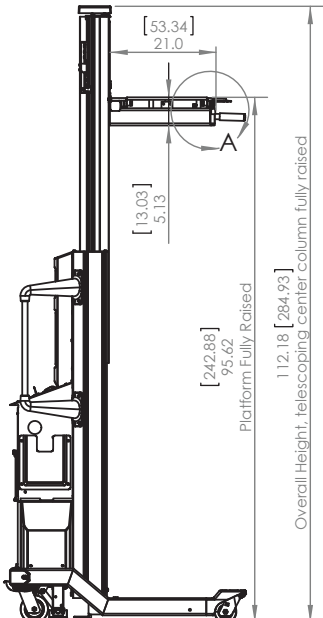
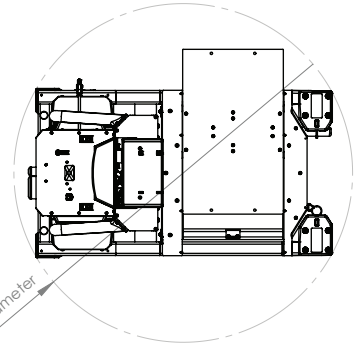

Product Dimensions	US	Metric
Unit Height (Lowered)	5' 9.4"	1.76m
Unit Height (Raised)	9' 4.2"	2.85m
Length	3' 8"	1.12m
Width	2' 0.5"	0.62m

Capacity and Weight	US	Metric
Capacity at Platform Center	500lb	226.8kg
Capacity at Platform Edge	300lb	136.1kg
Total Unit Weight	428lb	194.0kg
Rated Cable Failure Load	4000lb	1814kg

## Dimensions and Capacity, SL-1000X®

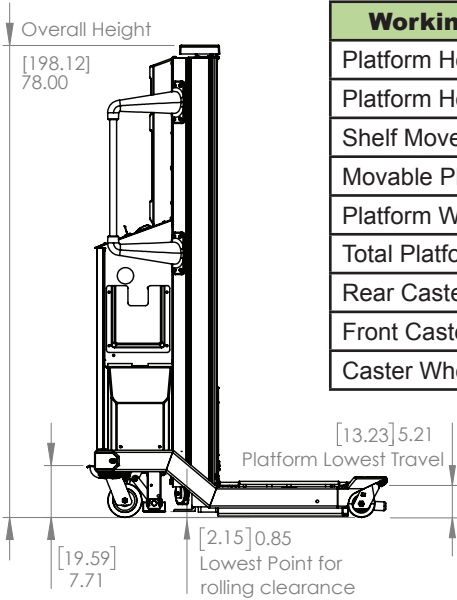

Working Dimensions	US	Metric
Platform Height, Extended	8.73'	2.66m
Platform Height, Lowered	5.21"	13.2cm
Shelf Movement per side	6.0"	15.2cm
Movable Platform Width	14.0"	35.6cm
Platform Width	24"	61.0cm
Total Platform Depth	21"	53.0cm
Rear Caster Wheel Diameter	5"	12.7cm
Front Caster Wheel Diameter	5"	10.2cm
Caster Wheel Width	2"	5.08cm

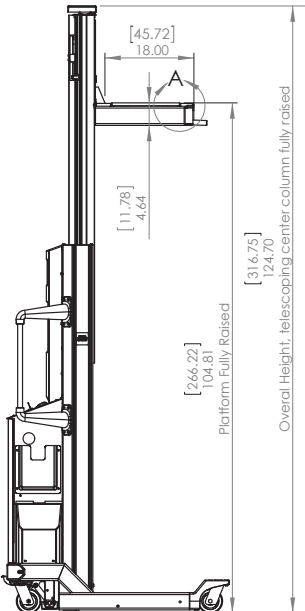
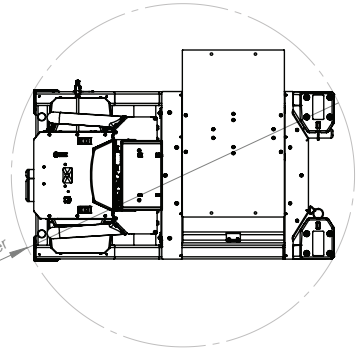

Product Dimensions	US	Metric
Unit Height (Lowered)	6' 5"	1.98m
Unit Height (Raised)	10' 4.7"	3.17m
Length	3' 11.3"	1.20m
Width	2' 0.5"	0.62m

Capacity and Weight	US	Metric
Capacity at Platform Center	1000lb	453.6kg
Capacity at Platform Edge	400lb	181.4kg
Total Unit Weight	539lb	244.5kg
Rated Cable Failure Load	7000lb	3175kg

## Battery Does Not Charge

Possible Cause	Solution
Power not being supplied to the charger.	Check that Power Cord is plugged in to a live outlet within appropriate Voltage Input Range. If using an extension cord, check that it is working.
Battery Quick Disconnect loose or not connected.	Connect Battery Quick Disconnect.
Failed Battery.	Test Battery. Replace Battery if necessary.
Failed Charger.	If plugged in to a power source outside appropriate Voltage Input Range, Charger will fail. Check top of Charger from inside access panel. If plugged in and no lights are on, replace Charger.

## Stabilizer Brake Does Not Work

Possible Cause	Solution
Stabilizer Brake Boot(s) missing	Replace Stabilizer Brake Boot(s)
Operating on uneven floor.	Make sure unit is on even floor. Do not operate unit on uneven floor
Stabilizer Brake latch not engaging/locking.	Check undercarriage of unit to see if Stabilizer Brake latch is engaging. If it does not contact ServerLIFT Service & Support.

## Front Caster Wheels Do Not Lock

Possible Cause	Solution
Locking pin not engaging with caster groove.	Make sure there are no obstructions between pin and groove. Adjust caster wheel until engagement occurs. Detailed directions for this adjustment available from ServerLIFT Service & Support.
Caster groove or locking pin worn or damaged.	Replace worn or damaged hardware.

## Power On Indicated; No Functionality

Possible Cause	Solution
Low Battery charge.	Test and charge Battery. If Battery does not charge, follow troubleshooting above.
Wiring not connected to Main Circuit Board.	Open Panel Access Door. Check that all connections to Main Circuit Board are secure.
Main Circuit Board damaged.	Contact ServerLIFT Service & Support for replacement part. Replace Circuit Board.
Upper and/or Lower Limit Switches are activated.	Follow <i>Raises But Does Not Lower</i> and <i>Lowers But Does Not Raise</i> troubleshooting.

## No Power Indicated; No Functionality

Possible Cause	Solution
Low Battery charge.	Test and charge Battery. If Battery does not charge, follow troubleshooting above.
Keylock Switch not turned to the ON position.	Turn Keylock Switch to ON position.
Battery is not connected.	Open Panel Access Door. Connect Battery Quick Disconnect to mating receptacle.
Wiring not connected to Main Circuit Board.	Open Panel Access Door. Check that all connections to Main Circuit Board are secure.
Main Circuit Board damaged.	Contact ServerLIFT Service & Support for replacement part. Replace Circuit Board.

## Up/Down Switch(es) Does Not Work

Possible Cause	Solution
No power to unit.	Follow <i>No Power Indicated</i> troubleshooting above.
Wiring to Switch(es) loose or not connected.	Open Panel Access Door. Check that all connections to Switch(es) are secure.
Switch(es) have failed.	Contact ServerLIFT Service & Support for replacement part(s). Replace Switch(es).

## Platform Raises But Does Not Lower

Possible Cause	Solution
Platform is obstructed.	Remove obstruction from below Platform.
Lower Limit Switch is stuck in the engaged/depressed position.	If Platform is not in its lowest position and there are no obstructions below it, remove Upper Panel Cover. Make sure all electrical connections to Lower Limit Switch are secure. Make sure Lower Limit Switch plunger is not stuck in depressed position. SL-500X®: make sure Tension Swing Arm <b>is not</b> engaging/depressing the switch plunger. SL-1000X®: make sure Tension Swing Arm <b>is</b> engaging/depressing the switch plunger.
Main Circuit Board damaged.	Contact ServerLIFT Service & Support for replacement part. Replace Circuit Board.

## Platform Lowers But Does Not Raise

Possible Cause	Solution
TouchSTOP™ Sensor binding and stuck in engaged position.	Make sure no obstructions are binding TouchSTOP™ Sensor mechanism and mechanism is tightly secured. Manually unbind mechanism and ensure it travels down and springs back freely.
Upper Limit Switch is stuck in the engaged/depressed position.	To expose Upper Limit Switch, unscrew TouchSTOP™ Sensor mechanism retaining screws. These are accessed from two holes on top of TouchSTOP™ Sensor. Carefully pull TouchSTOP™ Sensor mechanism slightly away from top of Vertical Mast. Locate Upper Limit Switch and make sure switch plunger is not stuck in depressed position.
Damaged Circuit Board.	Replace Circuit Board.

## Shelf Handle Won't Lock in Place

Possible Cause	Solution
Locking mechanism is damaged.	Check under Platform for damaged part(s). Contact ServerLIFT Support for replacement part.

## Easy-Glide Shelf Does Not Side Shift

Possible Cause	Solution
Handle is not unlocked from its position.	Press handle down. Attempt to shift Shelf sideways.
Path of shelf is obstructed.	Locate and remove obstruction(s).
Locking mechanism is damaged.	Check under Platform for damaged part(s). Contact ServerLIFT Support for replacement part.

## Keylock Spins 360 Degrees

Possible Cause	Solution
Keylock D-groove damage or missing.	Replace Main Control Panel plate.
Keylock nut loose.	Tighten nut on underside of Main Control Panel and make sure Keylock wiring is secure.

## ServerLIFT Does Not Move/Roll

Possible Cause	Solution
Stabilizer Brake is engaged.	Disengage Stabilizer Brake.
Obstruction with caster wheel.	Remove obstruction.
One or more caster wheels damaged.	Replace damaged hardware.

## ServerLIFT Does Not Swivel/Turn

Possible Cause	Solution
Front Swivel Lock(s) engaged.	Disengage Swivel Lock(s).
Obstruction with caster wheel.	Remove obstruction.
One or more caster wheels damaged.	Replace damaged hardware.



## SL-500X®, SL-1000X® SERVERLIFT LIMITED WARRANTY

### LIMITED WARRANTY COVERAGE

The limited warranty covers defects in materials and workmanship of the SL-500X®, or SL-1000X® ServerLIFT (collectively “Equipment”). The warranty is not transferable. The warranty applies only to the original end-user owner of the Equipment unless prior written notice is received by and approval given by ServerLIFT.

For the Warranty Periods listed below, ServerLIFT Corporation (henceforth “ServerLIFT”) warrants that the Equipment:

1. Will be free from defects in materials and workmanship.
2. Will perform substantially in accordance with ServerLIFT’s published specifications.

ServerLIFT will ship any parts that are in-warranty at no charge in accordance with the Limited Warranty Return & Repair Policy listed below. ServerLIFT will provide repair or replacement instructions as needed.

### LIMITED WARRANTY PERIODS

The Warranty Period is one year from the day of delivery except for the following components:

<u>Component/Equipment</u>	<u>Warranty Period</u>
Structural	10 years
Battery	1 year <sup>1</sup>

<sup>1</sup> 100% (part cost only) for first three months, prorated against replacement three months to one year.

### LIMITED WARRANTY EXCLUSIONS

The warranty is void if:

- The applicable Warranty Period has expired;
- The Equipment has missing or altered serial numbers; or
- The Equipment has been repaired or modified by an agent not authorized by ServerLIFT.

The warranty specifically excludes damage to the Equipment, including but not limited to:

- Damage incurred during shipment (other than shipping with a ServerLIFT contracted carrier);
- Damage caused by impact with other objects, drops or falls, including external case cracks, dented or punctured case, broken latches, torn covers, broken doors, or physical breakaway of internal components;
- Damage caused by intrusion of foreign matter into the Equipment;
- Damage to internal components caused by power surge;
- Damage to electrical connectors including corrosion, broken and/or bent pins;
- Damage to Equipment caused by environmental corrosion;
- Damage caused by improper maintenance;
- Damage caused by use of appurtenances not supplied by ServerLIFT or failures which result from alterations, modifications or foreign objects;
- Damage caused by the use of the Equipment for purposes other than for which it was designed
- Damage caused by other abuse, misuse, neglect, accident, negligence, mishandling or misapplication; and
- Damage attributable to acts of G-d.

## LIMITED WARRANTY RETURN & REPAIR POLICY

For warranty assistance call ServerLIFT Corporation at 1-602-254-1557 between 9:00 AM and 5:00 PM Mountain Standard Time, Monday through Friday (excluding observed holidays), email [support@serverlift.com](mailto:support@serverlift.com) or visit <http://serverlift.com/support/>.

Equipment that fails to comply with this warranty shall, at ServerLIFT's sole discretion, be repaired or exchanged for an equivalent replacement. You are responsible for returning the non-conforming Equipment, properly packaged, to ServerLIFT during the Warranty Period. ServerLIFT will pay return shipping costs of Equipment serviced under the Limited Warranty.

To obtain warranty service or to return Equipment, written notification must be made to ServerLIFT in advance via email ([support@serverlift.com](mailto:support@serverlift.com)) or fax (1-602-412-4479) that must include the following information:

- Equipment serial number;
- Date of original Equipment receipt;
- Original ServerLIFT invoice and/or invoice number (proof of purchase);
- Contact information of the end-user and location of Equipment; and
- Description of the problem and/or desired service action.

In the event of a return or repair that is determined to occur at ServerLIFT's facilities, you will be issued a Warranty Repair Authorization (WRA) number and shipping instructions. Otherwise, ServerLIFT will arrange onsite service based on a mutually convenient schedule.

Equipment returned with a void warranty and/or without prior notification to and approval from ServerLIFT may be repaired and/or shipped back to the end-user at their expense.

If it is determined that the problem is not covered under warranty, you will be contacted with service alternatives available on a time and materials basis. You will also be responsible for all applicable shipping costs.

## WARRANTY LIMITATIONS

IN NO EVENT SHALL SERVERLIFT BE LIABLE, WHETHER IN CONTRACT, NEGLIGENCE, TORT, OR ON ANY OTHER BASIS, FOR COVER OR FOR INCIDENTAL, CONSEQUENTIAL OR EXEMPLARY DAMAGES ARISING OUT OF OR IN CONNECTION WITH THE SALE, SERVICES, MAINTENANCE, USE, PERFORMANCE, FAILURE, OR INTERRUPTION IN THE OPERATION OF EQUIPMENT, SERVICES, HARDWARE OR SOFTWARE, EVEN IF SERVERLIFT IS ADVISED OF THE POSSIBILITY OF SUCH DAMAGES. THE WARRANTY IS IN LIEU OF ALL OTHER WARRANTIES, WHETHER EXPRESS, IMPLIED OR STATUTORY. SOME STATES DO NOT ALLOW LIMITATIONS ON IMPLIED WARRANTIES SO THIS LIMITATION MAY NOT APPLY TO YOU.

This warranty and performance hereunder shall be governed by and construed in accordance with the laws of the State of Arizona without reference to its choice of law principles.

## WARRANTY EXTENSIONS AND SERVICE CONTRACTS

Extended warranty periods and service contracts are available to suit your specific needs. To learn more about these optional service programs contact ServerLIFT Service & Support via email ([support@serverlift.com](mailto:support@serverlift.com)) anytime or by phone (1-602-254-1557) 9:00 AM to 5:00 PM Mountain Standard time, Monday through Friday (excluding observed holidays).



## **Declaration of Conformity**

**Manufacturer:** ServerLIFT Corporation  
17453 N 25th Ave  
Phoenix, AZ 85023 USA  
602-254-1557  
www.serverlift.com

**Model numbers:** SL-500X®, SL-500XI™

**Max. Load Capacity:** 227 kg (500 lbs)

**Type of equipment:** Server and IT equipment lifting machine

We declare that the product identified above meets the requirements of the following EU directives and standards for the purpose of CE compliance:

### **Directives/Standards:**

#### **Immunity Standards**

##### **IEC/EN 61000-6-1: 2007**

Immunity for residential, commercial and light-industrial environments

#### **Emissions Standards**

##### **IEC/EN 61000-6-3: 2007**

Residential, commercial and light-industrial environments

##### **IEC/EN 55011:2009/A1: 2010**

Industrial, scientific & medical equipment for radio-frequency disturbance characteristics

#### **Product Safety Directives**

##### **Machinery Directive 2006/42/EC**

**Low Voltage Directive (LVD) 2006/95/EC, IEC EN 60950**

Name: Mr. Raymond Zuckerman

Title: CEO

Date: 09/08/2014



## **Declaration of Conformity**

**Manufacturer:** ServerLIFT Corporation  
17453 N 25th Ave  
Phoenix, AZ 85023 USA  
602-254-1557  
www.serverlift.com

**Model numbers:** SL-1000X®, SL-1000XI™

**Max. Load Capacity:** 454 kg (1000 lbs)

**Type of equipment:** Server and IT equipment lifting machine

We declare that the product identified above meets the requirements of the following EU directives and standards for the purpose of CE compliance:

### **Directives/Standards:**

#### **Immunity Standards**

##### **IEC/EN 61000-6-1: 2007**

Immunity for residential, commercial and light-industrial environments

#### **Emissions Standards**

##### **IEC/EN 61000-6-3: 2007**

Residential, commercial and light-industrial environments

##### **IEC/EN 55011:2009/A1: 2010**

Industrial, scientific & medical equipment for radio-frequency disturbance characteristics

#### **Product Safety Directives**

##### **Machinery Directive 2006/42/EC**

##### **Low Voltage Directive (LVD) 2006/95/EC, IEC EN 60950**

Name: Mr. Raymond Zuckerman

Title: CEO

Date: 09/08/2014



## **Declaration of Conformity**

**Client:** ServerLIFT Corporation

**Model numbers:** SL-500X®, SL-500XI™, SL-1000X®, SL-1000XI™

**Type of equipment:** Lifting device for IT equipment for use in data centers

**Manufacturer:** ServerLIFT Corporation  
17453 N 25th Ave, Phoenix, AZ 85023 USA  
602-254-1557

**Report Date:** February 24, 2012

**Test Performed By:** Compliance Testing LLC  
3356 N San Marcos Place, Suite 107  
Chandler, AZ 85225  
Ph: (480) 926-3100

**Report Date:** FCC Part 15B, Class B

### **FCC 15.19(a) (3):**

This device complies with part 15 of the FCC Rules.

Operation is subject to the following two conditions:

1. This device may not cause harmful interference, and
2. This device must accept any interference received, including interference that may cause undesired operation.

Name: Mr. Raymond Zuckerman

Title: CEO

Date: 09/08/2014

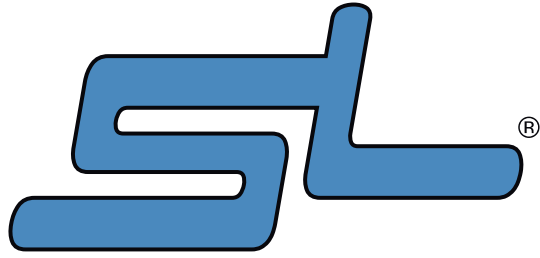

**serverLIFT**

---

[www.serverlift.com](http://www.serverlift.com)

---

© ServerLIFT Corporation 2017. All Rights Reserved.

SL, SL-1000X, SL-500X, SL-350X, and TouchSTOP are trademarks of ServerLIFT Corporation