

SOLAR

Clean Energy PoE Switch

➤ User Manual

DIREKTRONIK

Direktronik AB tel. 08-52 400 700 www.direktronik.se

Overview



Having the features that power generation by solar energy, intelligent PoE power supply and control on auto charging and discharging, 5+1 high-power solar energy charging switch can more effectively solve the network application and power supply demand in complicated environments such as in remote mountainous areas, scenic spots, network electricity off shore and outdoor construction.

Function

- ◆ Auto charging and discharging.
- ◆ Battery voltage auto detection.
- ◆ Support lead-acid and lithium battery(MAX 50AH).
- ◆ Support 12V/24V solar panel input(MAX 400W).
- ◆ Intelligent PSE chip.
- ◆ PoE standard:IEEE 802.3af/at/PoE++.
- ◆ High-power output(first port can output HiPoE,MAX 60W).
- ◆ 4-5 port 24V/48V adaptive output.
- ◆ REALTEK intelligent CPU chip.

Display&Description

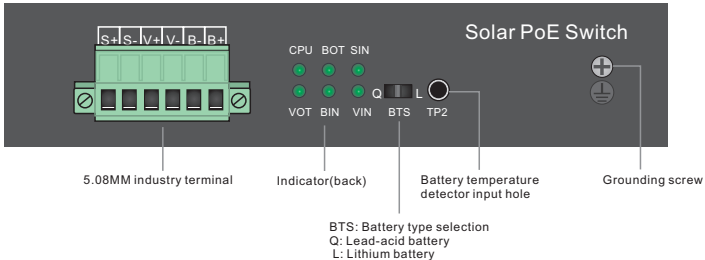
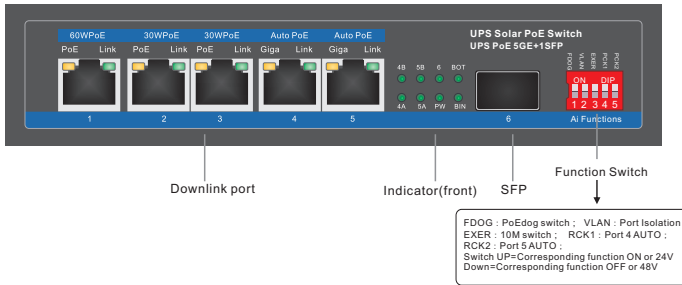

Indicator

Indicator(front)		Status	Description
Power LED:PW		Always ON	Normal
		Always OFF	Power unconnected
Downlink LED	Orange (PoE)	Always ON	Powered devices connected and power supply normal
		Always OFF	No powered devices connected or no power supply
	Green (Link)	Always ON	Network signal communicated
		Always OFF	Network signal not communicated
SFP LED:6		Always ON	SFP normally connected
		Always OFF	SFP abnormally connected

Indicator(front)	Status	Description	Indicator(front)	Status	Description
4B: 4 port 24V PoE	Always ON	24V PoE power supplied	5B: 5 port 24V PoE	Always ON	24V PoE power supplied
	Always OFF	24V PoE no power supplied		Always OFF	24V PoE no power supplied
4A: 4 port 48V PoE	Always ON	48V PoE power supplied	5A: 5 port 48V PoE	Always ON	48V PoE power supplied
	Always OFF	48V PoE no power supplied		Always ON	48V PoE no power supplied
BOT:Discharging LED	Always ON	Battery in charging,electricity>15%	BIN: Charging LED	Always ON	Battery in charging,electricity<98%
	Always OFF	Battery discharging finished or not discharging		Always OFF	Battery charging or not in charging
	Flicker	1/2S:electricity<15%		Flicker	To be fully charged,electricity≥98%

BOT,BIN OFF at once : charging finished

Indicator(back)	Status	Description	Indicator(back)	Status	Description
CPU: System operation LED	Always ON	System crashed	SIN: Solar energy IN LED	Always ON	Solar energy input normal
	Always OFF	System unsuccessfully started		Always OFF	Solar energy not input
	Flicker	1/2S: battery normal 1/4S: battery failure		Flicker	1/2S:solar energy in delayed charging(time:10 mins) 1/4S:solar energy voltage input fault,charging stopped
BOT: Discharging LED	Always ON	Battery in discharging, electricity>15%	BIN: Charging LED	Always ON	Battery in charging, electricity<98%
	Always OFF	Battery discharging finished or not in discharging		Always OFF	Battery charging finished or not in charging
	Flicker	1/2S: electricity<15%		Flicker	To be fully charged,electricity≥98%
VOT: PoE voltage normal LED	Always ON	PoE voltage normal	VIN: DC IN LED	Always ON	DC IN normal
	Always OFF	PoE voltage abnormal		Always OFF	DC not input
				Flicker	DC IN voltage fault, charging stopped

Description of Terminal Connection

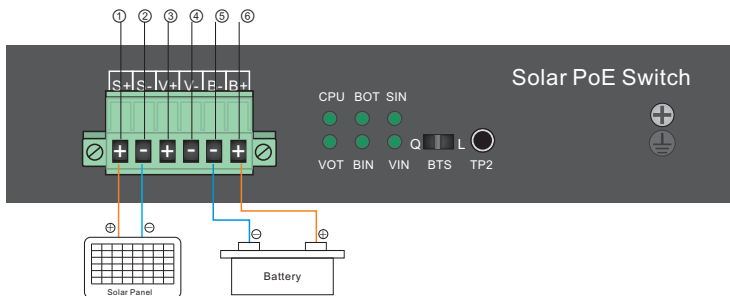

Note: ① S+ : solar energy anode ② S-: solar energy cathode ③ V+ : DC anode
④ V-: DC cathode ⑤ B-: battery cathode ⑥ B+ : battery anode

Battery + Solar Panel Matching-usage Description

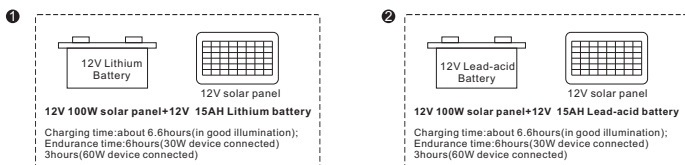

Tips: The open-circuit voltage is 32V maximum and operating voltage is 18.5V.
(Please refer to actual configuration to get the specific solar panel power)

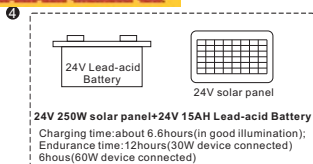
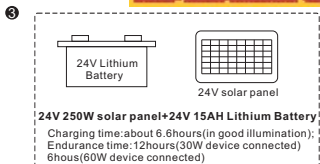

Tips: The open-circuit voltage is 45V maximum and operating voltage is 37V.
 (Please refers to actual configuration to get the specific solar panel power)

Charging time computational formula = Battery AH (solar energy short-circuit current * 0.55)

Discharging time computational formula = (Battery rated voltage * battery AH) / actual discharging power

The above computational results are only a reference of configuration and installation requirements. Please accord to comprehensive factors such as local environment, light, weather and etc. when you use.

Application

Connection Schematic Diagram

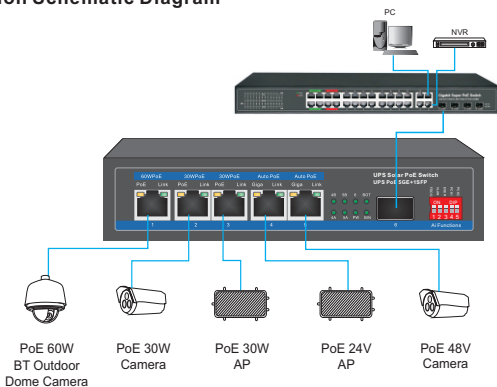

Scene Schematic Diagram

—BT Dome Camera Application in Scenic Spot

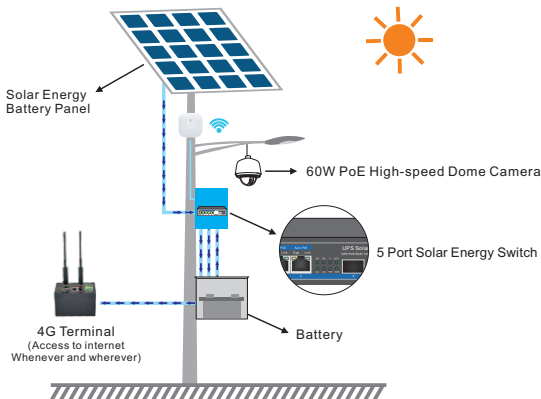

Model	5GE PoE+1SFP-BT
Product	5+1 High-power Solar Energy PoE Switch
Port	1* 10/100/1000Base-TX 60W PoE port ■Data/Power ■ 2* 10/100/1000Base-TX 30W PoE port ■Data/power ■ 2* 10/100/1000Base-TX Auto PoE port ■Data/power ■ 1* 1000M SFP
PoE Port	1port: Ai version HiPoE, port output power MAX 60W 2-3port: IEEE 802.3af/at, port output power MAX 30W 4-5port: Auto Ai version PoE port(supply power for 48V/24V devices), port output power MAX 25W 1-5 port support PoE(first port output HiPoE_60W)
Function	Q_Lead-acid battery mode+L_Lithium battery mode
Network Protocol	IEEE 802.3 IEEE 802.3i 10BASE-T IEEE 802.3u 100BASE-TX IEEE 802.3ab1000BASE-T IEEE 802.3x IEEE 802.3z 1000BASE-X IEEE 802.3af/at/PoE++ AI PSE
PoE Standard	IEEE802.3af/at/PoE++/HiPoE
Port Specification	10/100/1000BaseT(X)Auto
Transmission Mode	Store and Forward(full wirespeed)
Bandwidth	12Gbps
Packet Forwarding	8.64Mpps
MAC Address	2K
Buffer	2.5M
Transmission Distance	10BASE-T : Cat3,4,5 UTP(≤250 meter) 100BASE-TX : Cat5 or later UTP(150 meter) 1000BASE-TX : Cat6 or later UTP(150 meter) 1000BASE-SX:62.5µm/50µm MMF(2m~550m) 1000BASE-LX:62.5µm/50µm MM(2m~550m) or 10µm SMF(2m~5000m) Maximum Supporting Transmission Distance 120KM for Single Mode Optical Fiber
Transmission Speed	Ethernet 10Mbps half duplex,20Mbps full duplex Fast Ethernet 100Mbps half duplex, 200Mbps full duplex Gigabit Ethernet 2000Mbps full duplex
Power Pin	48V power supply:12+36-; 24V power supply:45+78-
Power Input	Support 12V solar panel input(≤33V) or with12V batteries Support 24V solar panel input(≤44V) or with 24V batteries 12V battery DC input:DC 15-26V;24V battery DC input:26-32V
Charging Function	Integrated fully automatic charging Integrated battery protection function Automatic Battery Voltage Recognition Integrated Lithium Battery Automatic Activation System Integrated Low Volume Start-up Protection System
Battery	Supporting 12V or 24V lead-acid batteries MAX 50AH, 5A Supporting 12V or 24V lithium batteries MAX 50AH, 5A
LED Indicator	PW:Power LED; BIN:Battery charging indicator; BOT:Battery discharging indicator; 6:(SFP LED); 4A-5A:Port 4-5 48V PoE ON light; 4B-5B:Port 4-5 24V PoE ON light CPU:System operation LED; VOUT:PoE output VOL normal indicator; SIN:Solar panel input indicator; VIN:DC input indicator
Operating Temperature/ Humidity	-20 ~ +65°C; 10% ~ 90% RH Non coagulation
Storage Temperature/ Humidity	-40 ~ +70°C; 5% ~ 90% RH Non coagulation
Product Size/ Packing Size(L*W*H)	160mm*142mm*35mm 300mm*175mm*100mm
N.W (kg)	0.72kg(Solar energy panel, battery and power adapter are excluded in the product)
Installation	Rack-mount or wall mounting
Lightning Protection Level	3KV 8/20us; IP30
Certificate	CE mark, commercial; CE/LVD EN60950; FCC Part 15 Class B; RoHS;
Warranty	Whole device for 1 year(accessories not included)



Generator Control Panel Parameter

Battery	Lead-acid Battery		Lithium Battery	
Battery Voltage	12V	24V	12.6V	25.2V
Charging Mode	PWM (Current and voltage limit-constant current-voltage limit-voltage and current limit-floating charge)		PWM (Current and voltage limit-constant current-voltage limit)	
Self-consumption Supplement	+			
Self-consumption Detection Voltage	<12.6V	<25.2V	12.2V	24.4V
Rated Charging Current	5A			
Floating Charge Current	50mA-1000mA		—	
Floating Charge Time	3hours		—	
Charging Ending	Floating charge timing reached		Rated voltage, charging current<10mA	
Rated Discharging Current	6.5A	3.6A	8.5A	4A
POE Output Current	MAX1.25A			
POE Output Voltage	48~56V			
Maximum Photovoltaic Voltage	32V	44V	32V	44V
Maximum Charging Voltage	14.7V	29.6V	12.6V	25.2V
Floating Charge Voltage	13.7V	27.4V	—	—
Cut-off Discharging Voltage	10.1V	20.2V	8V	16V
Recovery Discharging Voltage	12.4V	25.8V	—	—
IIC Communication	IIC communication query and configuration of electricity, voltage, current, charging and discharging time and operating status			
Over-temperature Protection	Main board over temperature protection and battery over temperature(optional)			
Input Protection	Over-current, over-voltage, delayed start-up and anti-reversal protection			
Output Function	Over-current, over-voltage, short-circuit			
Indicator	System normal operation indicator, battery indicator, normal input indicator, multi-function failure indicator			
Operating Temperature	-30°C +65°C			

Attentions

1. Please read the operating instructions carefully before using, or improper operation may cause damage to machine components.
2. Do not use in places near fire sources.
3. Do not throw it in the water and also wet the internal component in the machine.
4. Do not shorting the positive and negative poles of the battery interface with metal conductors.
5. Do not disassemble or dissect the internal parts of the product. If there is any damage, the manufacturer will not implement the underwriting regulations.

Accessories List

<p>▶ 1* Switch</p> 	<p>▶ 1* User Manual+Warranty Card</p> 	<p>▶ Optional Wall hangers</p> 
--	---	--