

**PLIOGRIP**

**Material:** POM  
**Operating temperatures:** -40 to +90°C  
**Flame resistance:** HB UL94

**Application:** applied by clipping direct to wires and cables of sections 0,15 - 6 mm<sup>2</sup> before or after connection.

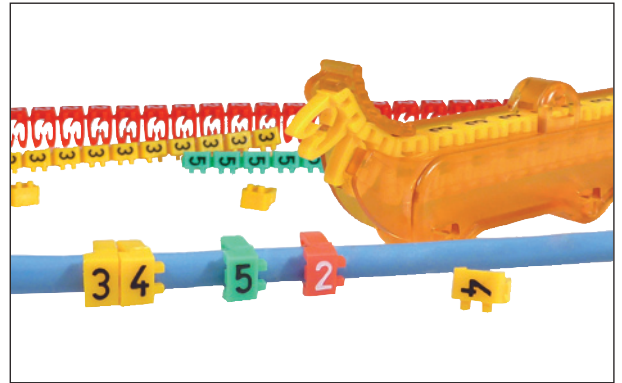

Other symbols upon request.

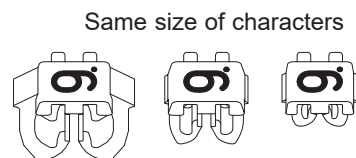
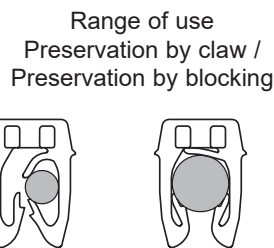
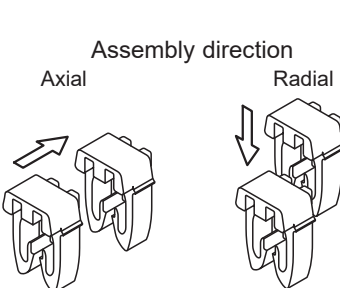
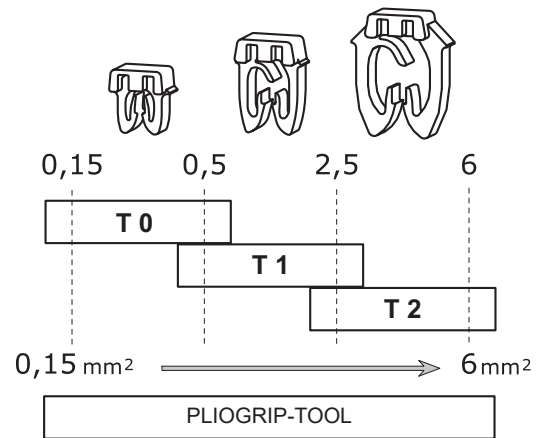

Operating instruction in video



## Markers PLIOGRIP

Example for order:

code group	detail article	code colour	code marker
0376	0010	X	X
0376	0011	X	X
0376	0012	X	X

T0 0376 0010 001 F

T1 0376 0011 004 TER

T2 0376 0012 005 3

### detail article

type	article number		mm	section mm <sup>2</sup>	numerical markers	alphabetical markers symbols and unprinted
	white / yellow *	colours				
T0	0376 0010	0376 0020	0,8 - 2,2	0,15 - 0,5	1000	300
T1	0376 0011	0376 0021	2,2 - 3,8	0,5 - 2,5	1000	300
T2	0376 0012	0376 0022	3,8 - 5,3	2,5 - 6	800	200

\* Markers L1 L2 L3, PE are only available for models T1 and T2.

### code colours

<b>010</b>	<b>006</b>	<b>007</b>	<b>005</b>	<b>004</b>	<b>003</b>	<b>002</b>	<b>008</b>	<b>013</b>	<b>001</b>
black	brown	red	orange	yellow	green	blue	violet	grey	white

### code markers

A	A	0376 **** * A
B	B	0376 **** * B
C	C	0376 **** * C
D	D	0376 **** * D
E	E	0376 **** * E
F	F	0376 **** * F
G	G	0376 **** * G
H	H	0376 **** * H
I	I	0376 **** * I
J	J	0376 **** * J
K	K	0376 **** * K
L	L	0376 **** * L
M	M	0376 **** * M
N	N	0376 **** * N
O	O	0376 **** * O
P	P	0376 **** * P
Q	Q	0376 **** * Q
R	R	0376 **** * R
S	S	0376 **** * S
T	T	0376 **** * T
U	U	0376 **** * U
V	V	0376 **** * V
W	W	0376 **** * W
X	X	0376 **** * X
Y	Y	0376 **** * Y
Z	Z	0376 **** * Z
0	0	0376 **** * 0
1	1	0376 **** * 1
2	2	0376 **** * 2
3	3	0376 **** * 3
4	4	0376 **** * 4
5	5	0376 **** * 5
6	6	0376 **** * 6
7	7	0376 **** * 7
8	8	0376 **** * 8
9	9	0376 **** * 9
/	/	0376 **** * /
.	.	0376 **** * .
+	+	0376 **** * +
-	-	0376 **** * -
~	~	0376 **** * ALT
⊥	⊥	0376 **** * CRE
⊥	⊥	0376 **** * TER
⊕	⊕	0376 **** * TEP
⊖	⊖	0376 **** * MAS
L1	L1	0376 **** * L1
L2	L2	0376 **** * L2
L3	L3	0376 **** * L3
PE	PE	0376 **** * PE
0	0	0376 **** 010 0
1	1	0376 **** 006 1
2	2	0376 **** 007 2
3	3	0376 **** 005 3
4	4	0376 **** 004 4
5	5	0376 **** 003 5
6	6	0376 **** 002 6
7	7	0376 **** 008 7
8	8	0376 **** 013 8
9	9	0376 **** 001 9
+	+	0376 **** 007 +
-	-	0376 **** 002 -
		0376 **** 010
		0376 **** 006
		0376 **** 007
		0376 **** 005
		0376 **** 004
		0376 **** 003
		0376 **** 002
		0376 **** 008
		0376 **** 013
		0376 **** 001



Box available with a European suspension hole.

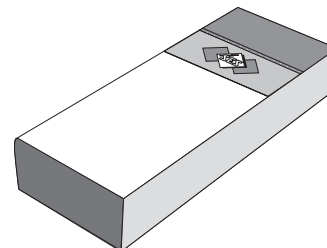

## • PLIOGRIP boxed kits

type	article number	 pce
KIT 1 PLIOGRIP T1	0376 8001 000	1
KIT 2 PLIOGRIP T2	0376 8002 000	1
KIT 3 PLIOGRIP T0	0376 8003 000	1



### Contents of the kits:

#### Kit 1 PLIOGRIP T1 :

- 8 tools 03760100000
- Markers T1 A → Z yellow 03760011004x - 100 pces/each
- Markers T1 0 → 9 CI 03760021xxx x - 100 pces/each

#### Kit 2 PLIOGRIP T2 :

- 8 tools 03760100000
- Markers T2 A → Z yellow 03760012004x - 100 pces/each
- Markers T2 0 → 9 CI 03760022xxx x - 100 pces/each

#### Kit 3 PLIOGRIP T0 :

- 8 tools 03760100000
- Markers T0 A → Z yellow 03760010004x - 100 pces/each
- Markers T0 0 → 9 CI 03760020xxx x - 100 pces/each

## • PLIOGRIP PSR marker carriers for the marking of large cables

There are two length of marker carriers available for size 0, and one length for size 1.

We recommend fixing markers with SES-QUICK cable ties width 2,4 and 2,6 mm type 100/25SL - 150/26SL - 200/26SL - 110/26SE (see pages C12/..).

type	article number	for markers	markers per wand	 pces
PSR-03-8	0374 0710 010	T0	8	100
PSR-03-15	0374 0720 010	T0	16	100
PSR-09-15	0374 0730 010	T1	17	100



## • Universal tool

Only one tool for 3 types of markers.

Ease of assembly of the markers per wand.

Ergonomics allowing the location of the cables on the top.

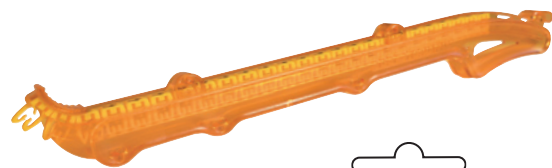

type	article number	 pces
PLIOGRIP-TOOL	0376 0100 000	10

 Box available with a European suspension hole.

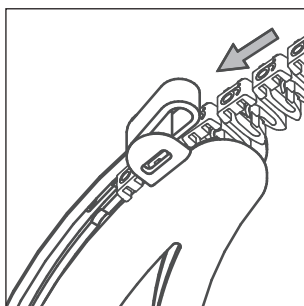

Ease of assembly

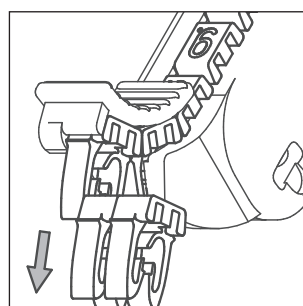

Radial assembly

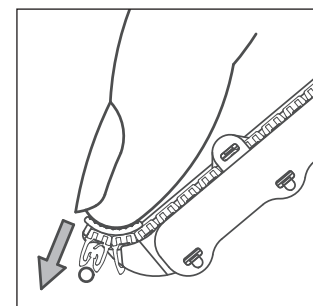

Ergonomics